



MASSEY FERGUSON

TO OUR CUSTOMER:

Congratulations on your selection of an MASSEY FERGUSON[®] product. We believe you have exercised excellent judgment in the purchase of your MASSEY FERGUSON[®] machine. We are most appreciative of your patronage.

Your Dealer has performed the pre-delivery service on your new machine.

He will discuss with you the operating and maintenance instructions given in this manual, and instruct you in the proper and varied applications of this machine. Call on him at any time when you have a question or need equipment related to the use of your machine.

We recommend that you carefully read this entire manual before operating the unit. Also, time spent in becoming fully acquainted with its performance features, adjustments, and maintenance schedules will be repaid in a long and satisfactory life of the product.

This equipment is covered by a written warranty which will be provided to you by your MASSEY FERGUSON[®] Dealer at time of purchase.

MASSEY FERGUSON[®] reserves the right to make changes or add improvements to its products at any time without incurring any obligation to make such changes to products manufactured previously. MASSEY FERGUSON[®], or its dealers, accept no responsibility for variations which may be evident in the actual specifications of its products and the statements and descriptions contained in this publication.

Massey Ferguson[®] is a worldwide brand of AGCO Corporation, Duluth, Georgia

EU Declaration of Conformity

Manufacturer

AGCO Feucht GmbH
Fellastraße 1-3
90537 Feucht
Germany

Product

Designation: Disc mower
Model: DM 306 TL
DM 306 TL-KC
DM 306 TL-RC

The machine meets the relevant provisions of the following directives:

- Machinery Directive 2006/42/EC

The following harmonized standards have been applied:

- DIN EN ISO 12100:2011
- DIN EN ISO 4254-1:2011
- DIN EN ISO 4254-12:2012

Feucht, 01/09/2016; Ulrich Nickol (Managing Director); Bernhard Kohl (Head of Design)

Contents

1	Introduction	3
2	Safety	5
2.1	Intended use	5
2.2	Reasonably foreseeable misuse	5
2.3	Warranty and liability	5
2.4	User qualifications	5
2.5	Warnings and symbols	6
2.6	Warning notices on the machine	7
2.7	Safety instructions	9
2.7.1	General safety instructions	10
2.7.2	Special safety instructions	11
3	Machine description	12
3.1	Product features	12
3.2	Notices on the machine	13
3.3	Special equipment	14
3.4	Machine components	15
4	Specifications	16
4.1	Machine data	16
4.2	Noise information	17
4.3	Axle loads, gross weight and minimum ballast required	18
5	Before initial operation	19
5.1	Assembling the machine	19
5.2	Adjusting the PTO shaft	19
6	Attachment to the tractor	21
6.1	Initial operation	21
6.2	Coupling the machine	21
6.3	Connecting the PTO shaft to the tractor	23
6.4	Connect hydraulics	24
6.5	Connecting the lighting	24
7	Transport position and working position	25
7.1	Switching the machine to transport position	25
7.2	Switching the machine to working position	26
8	Using the machine	27
9	Settings	28
9.1	Adjusting cutting height	28
9.2	Adjusting the ground pressure	28
9.3	Adjusting the tine rotor conditioner (KC)	29
9.3.1	Adjusting the conditioner intensity	29
9.3.2	Adjusting the swath guiding assembly	30
9.4	Adjusting conditioners with rubber rollers (RC)	30
9.4.1	Adjusting the conditioner intensity	30
9.4.2	Adjusting the swath guiding assembly	31
10	Optional functions	32

10.1	Greater cutting height using anti-wear skids	32
10.2	Swath guiding disc	32
10.3	KC spreader	32
11	Machine storage	33
12	Rectifying faults	35
12.1	If the machine runs over an obstacle	36
12.2	Adjusting the impact guard	37
12.3	Replacing the driveGUARD	37
12.3.1	Preparatory work	38
12.3.2	Mower disc without feed drum	38
12.3.3	Mower disc with feed drum	40
12.3.4	Checks after replacing a driveGUARD element	42
12.4	Overload protection system for the conditioner	42
12.5	Blockages at the conditioner	42
13	Servicing	43
13.1	Maintenance intervals	43
13.2	Accessing the maintenance points	44
13.3	Cleaning	45
13.4	Tightening torques for nuts and bolts	45
13.5	Adhesive notices on the machine	45
13.6	PTO shaft	46
13.7	Hydraulic system	46
13.8	Gearbox	48
13.8.1	Angle drive	48
13.8.2	Entry gearbox and cutter bar	48
13.9	Cutter blades	49
13.9.1	Checking the cutter blades	49
13.9.2	Checking the cutter-blade bolt	49
13.9.3	Checking the blade retaining bolt	50
13.9.4	Checking the holding spring	50
13.9.5	Replacing the cutter blades and/or cutter-blade bolt	50
13.9.6	Replacing the cutter blades	51
13.9.7	Replacing the blade retaining bolt and/or the holding spring	53
13.10	Screen element of the TurboLift system	54
13.11	Check the protective covers	54
13.12	Lubrication instruction	54
14	Index	60

1 Introduction

These operating instructions for the DM 306 TL disc mower contain detailed instructions and information regarding safe use, maintenance, special precautions and any special equipment that is available.

As a result of continuous further development of the machines, all technical data, figures and photos in these operating instructions are non-binding and we reserve the right to make changes. No alteration service is offered for these operating instructions.

 Note
In order to visualise it better, safety equipment and covers have been removed or opened in some of the illustrations or photos featured in these operating instructions.

 Warning!
Risk of injury from missing safety equipment.
There is a serious risk of injury if safety equipment and covers are not installed correctly, are not working properly or have been intentionally removed.
➔ All safety equipment and covers must be in good condition and closed before you operate the machine for the first time.

Operational instructions

The arrow➔ indicates an instruction for performing an operation.

➔ Always follow all operational instructions in the specified sequence.

Other applicable documentation

When operating the DM 306 TL disc mower, pay close attention to all operating instructions that are included with the other components of your mower.

Other applicable documentation includes:

- Operating instructions for the relevant PTO shaft,
- HYDAC operating instructions.

Storage of documentation

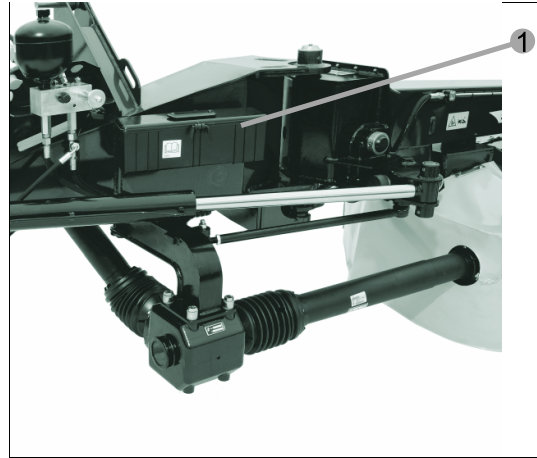



Fig. 1 Storage of documentation

Keep these operating instructions and all other relevant documentation in the document container (1) so that they are available on request. The document container is tightly screwed to the machine.

Applicability of the instructions

These operating instructions are only valid for DM 306 TL disc mowers as of the serial number that is specified on the back of these instructions. The serial number for your mower is shown under "Machine number" on the rating plate.

 Note
The DM 306 TL disc mower will also be referred to as "machine" in the following sections.

Introduction

Type plate and serial number

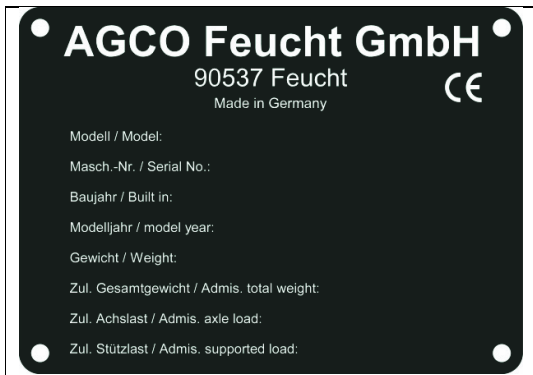

Fig. 2 Type plate



Fig. 3 Type Plate on the frame

The type plate (1) is riveted to the frame. It specifies the serial number.

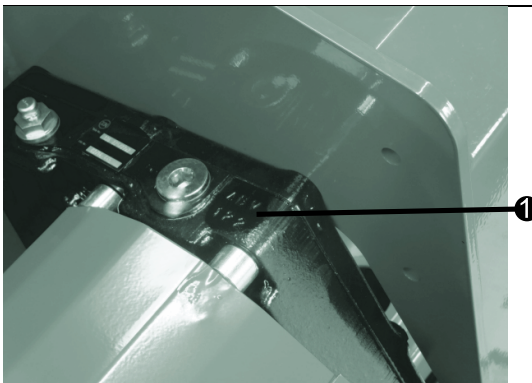

Fig. 4 Serial number

The serial number (1) is also stamped on the entry gearbox of the cutter bar.

2 Safety

2.1 Intended use

The disc mower is used to cut stalks that grow at ground level. For this, the machine must be in the working position. This machine has been constructed exclusively for normal use with agricultural or similar tasks.

Any other use beyond this is considered improper. The manufacturer accepts no responsibility for any damage caused by improper use. The user alone is responsible for this.

"Proper use" includes:

- Paying attention to all of the information on how to use the machine in the operating instructions,
- Taking all warnings into account and
- Carrying out all inspections and maintenance work as instructed when they are due.

2.2 Reasonably foreseeable misuse

Examples of improper use that may cause harm to the user, to others or to the machine during all modes of operation are:

- Not using the machine in accordance with the proper use,
- Changes to the machine, along with attachments and modifications without previously consulting the manufacturer,
- Not using the machine as instructed in the operating instructions, with regards to safety instructions, installation, operation and maintenance and repair,
- Bypassing or decommissioning the machine's protective and safety equipment,
- Using an obviously damaged or faulty machine and
- Repairing, cleaning or servicing the machine without switching it off.

2.3 Warranty and liability

The manufacturer's "General Terms and Conditions of Sale and Delivery" are generally applicable and will be available to the owner no later than the conclusion of the contract.

Warranty and liability claims for personal injury and material damage shall not be accepted if they are caused by one or several of the following:

- Improper use of the machine,
- Incorrect installation, first use, operation or maintenance of the machine,
- Using the machine regardless of damaged protection devices,
- Ignoring the information in the operating instructions and warnings about the machine,
- Unauthorised structural modifications to the machine or
- Insufficient maintenance measures carried out.

Read the operating instructions carefully before switching on or using the machine for the first time. The operating instructions help familiarise the user with the machine's operation and provide details about the performance and maintenance.

The operating instructions must be available to the user at all times and must be within reach, close by the machine.

The information regarding maintenance and operational safety that is provided in the operating instructions must be observed and complied with.

For any other questions that are not covered in these operating instructions, the manufacturer is always happy to help.

2.4 User qualifications

These operating instructions are intended for farmers who operate, service and hitch the machine to the tractor themselves, and also for other persons without agricultural training who use the machine. According to health and safety law, it is the responsibility of the owner to provide also any other users with the necessary information.

Safety

Necessary information is obtained from:

- Instruction and training in assigned tasks,
- Providing information about potential risks associated with improper handling and
- Instructions about:
 - The necessary protective equipment,
 - Protective measures
 - Applicable regulations
 - Accident-prevention legislation
 - Operating conditions.

It is assumed that the user is familiar with basic mechanics and hydraulics.

Any person using the machine (the user) must follow the operating instructions and observe the respective safety instructions for every task/activity.

As a basic prerequisite, the user must have valid authorisation for transporting the machine on the road using a tractor or appropriate towing vehicle in order to be allowed to transport such equipment on the roads.

2.5 Warnings and symbols

In these documents, each warning has a key word that indicates the extent of the risk involved.

The first few lines below the key word describe the **nature and source of the potential risks**.

The following section indicates the consequences that may occur if no measures for preventing the risk(s) are taken.

The final section outlines risk-prevention measures.

The following key words are used.

 Danger!
Situation posing an immediate hazard that could lead to serious injury or death if the respective warning is ignored.

 Warning!
Potentially hazardous situation leading to serious injury or death if the respective warning is ignored.

 Caution!
Potentially hazardous situation leading to minor or slight injury if the respective warning is ignored.

 Important!
Potentially hazardous situation leading to material damage if the respective warning is ignored.

 Note
Instructions for use and other useful information (not for hazardous or harmful situations).

Warnings on the machine (Fig. 5) alert you to hazards which could result in personal injury or material damage. These warnings must be observed.

2.6 Warning notices on the machine



Warning!

Risk of injury from illegible warnings.

Warnings and symbols on the machine draw attention to hazards. If warning signs affixed to the machine are no longer legible or are damaged/missing, they must be replaced without delay.

→ Always check the condition of warning signs affixed to the machine before each use.

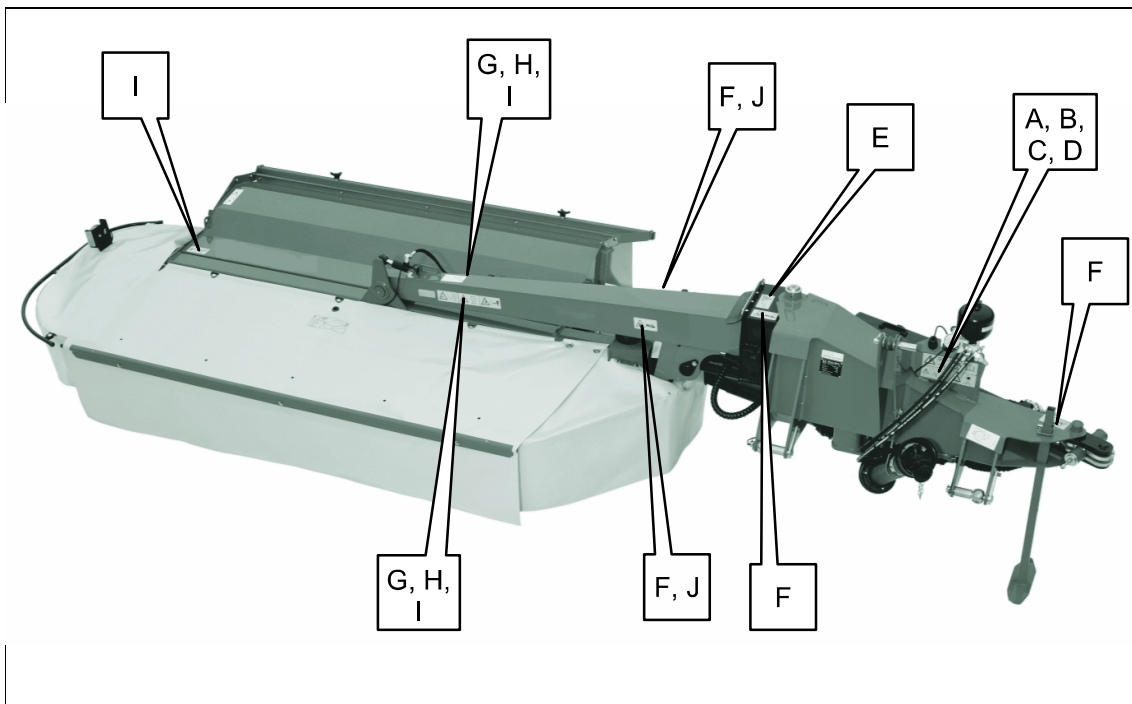

Fig. 5 Warning notices on the machine

Safety

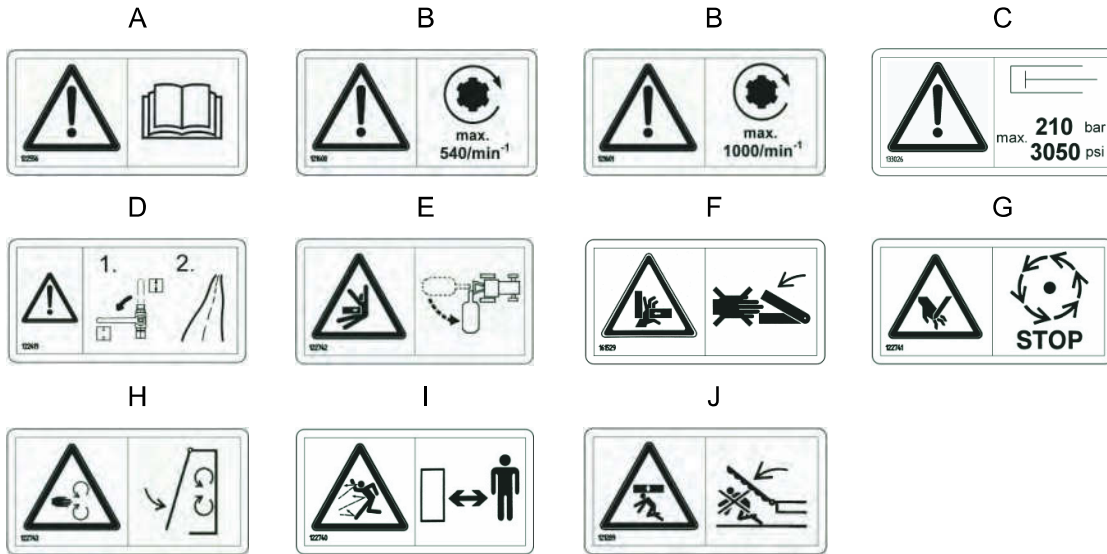

Fig. 6 Operating instructions

Before using the machine for the first time, **read** the operating instructions and safety instructions. Always **observe** the operating instructions and safety instructions while using the equipment.



Fig. 7 Drive speed

Do not exceed the maximum permitted drive speed of 540 rpm or 1000 rpm.



Fig. 8 Hydraulic pressure

Do not exceed the maximum permitted hydraulic pressure of 210 bar/3050 psi.

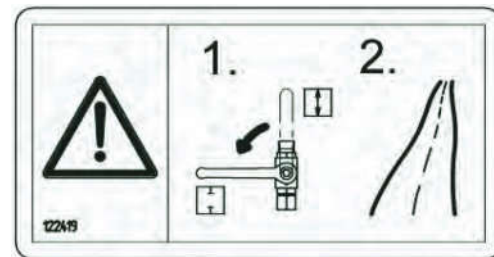

Fig. 9 Shut off the hydraulic line

Use the stop valve to **lock** the **hydraulic line** before travelling on the roads.



Fig. 10 Mower swivelling range

Keep out of the mower **swivelling range**.



Fig. 11 Risk of crushing

Never reach into the area where there is a risk of crushing while parts may still move in that area.



Fig. 12 Overrun time/wait until moving parts are stationary

Only approach when the machine's machine parts **have come to a complete stop**.

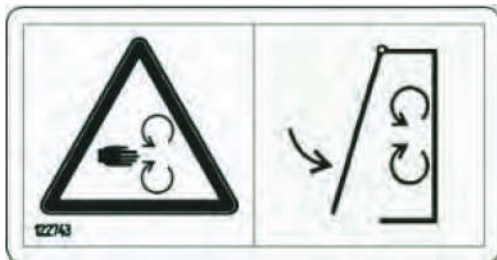

Fig. 13 Close the guard

Move the machine's **safety equipment to the safety position** before switching on the PTO shaft.

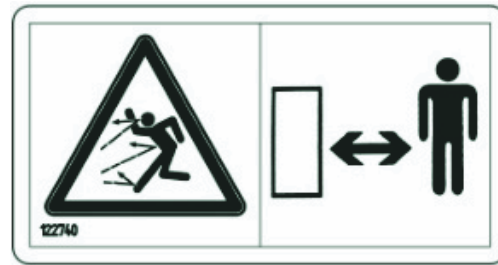

Fig. 14 Loose stones

Keep out of the hazard area. Please take particular care when working near roads and buildings.



Fig. 15 Swivelling range

Keep out of the swivelling range.

2.7 Safety instructions

Observing the safety instructions and warnings

The general safety instructions always apply for using the machine safely and maintaining it in a safe condition. The operating instructions and, in particular, all of the safety instructions contained therein, must therefore be read through before using the machine for the first time and kept in mind during use.

This helps to ensure that the machine is used safely, and protects both the user and people in the vicinity of the machine.

- ➔ When assembling, using, troubleshooting and servicing the machine, always observe the general safety instructions and the warnings and symbols which precede each operation.
- ➔ Observe all warnings and symbols attached to the machine.
- ➔ Observe all other safety regulations that are relevant to the machine, both general and region-specific.

Safety

2.7.1 General safety instructions

Preparing the machine for use

To avoid putting the user and other persons in danger, the machine must be prepared before each use.

- Before starting work, all users must ensure that they are familiar with all safety equipment, operating elements and their function.
- Check that the lighting equipment functions correctly.
- Test the protective equipment and move it to the respective prescribed operating position (transport position/working position).
- Check hydraulic hose lines before each use and replace them if they show any signs of damage or ageing.

Coupling/uncoupling the machine to/from the tractor

Take special care when coupling and uncoupling the machine.

- Make sure that there are no persons in the hazard area when manoeuvring. Instruct persons to leave the hazard area if necessary.
- When operating the tractor hydraulics, make sure that there are no persons within the movement range of the lower and upper links.
- After coupling the machine, fit the locking devices (spring cotters or cotter pins) correctly.

Machine operation

When the machine is in operation, the user must be able to reach in quickly at any time. There are moving working tools on the machine, which could cause injury to persons or even death.

- Only ever operate the machine from the tractor seat.
- Do not ride on the machine.
- Before pulling away, check the surrounding area.
- Ensure sufficient visibility.

- Make sure that no-one is in the pivoting or working area of the machine.
- Instruct persons to leave the hazard area.
- If you leave the tractor seat in order to carry out adjustments, the machine and the tractor engine must be switched off and the ignition key removed.

Driving on public roads and lanes

For driving on public roads and lanes, special national regulations apply. Other road users must also not be put in danger.

- Before driving on roads, check the condition and function of all signalling and lighting equipment.
- Clean dirty signalling and lighting equipment before driving off..
- To maintain steerability, the attached machine must never take too much load off the front wheels of the tractor. Fit loading weights at the front of the tractor if necessary.
- Keep permitted vehicle dimensions in mind.
- Observe the tractor's permissible axle loads and gross weights.
- On public roads and lanes, the machine must be driven in transport position only.
- Do not ride on the machine.

Maintenance work

It is necessary to perform maintenance work on the machine to guarantee that it is in a safe operating condition and to avoid any unnecessary repairs. Performing work incorrectly can lead to injuries.

- Before performing the maintenance work, switch off the tractor engine and remove the ignition key.
- Only perform maintenance work as described in these instructions.
- Any work that is not specified in these instructions must only be carried out by specialist personnel in a specialist workshop.

Unauthorised modifications or alterations

If unauthorised modifications or alterations are carried out, the machine can present a danger.

- ➔ Do not carry out any modifications or alterations to the machine if they have not been discussed with and authorised by the manufacturer.

What to do in an emergency

In the event of a dangerous situation, fast action is required to protect the user or anyone else from being injured.

- ➔ Switch off the tractor immediately.
- ➔ Contact the emergency services if necessary.

Fire prevention

Regular maintenance and cleaning of the machine will reduce the risk of fire.

- ➔ Remove harvesting residue from the machine.
- ➔ Listen for unusual noises every time you operate the machine.

2.7.2 Special safety instructions

 Warning!
<p>Risk of injury from substances that affect your awareness.</p> <p>Users must not be under the influence of alcohol or drugs as these can affect their reaction times or coordination. The same also applies for certain medicines.</p> <ul style="list-style-type: none"> ➔ Do not operate the machine after taking any substances that affect your awareness.

 Warning!
<p>Risk of injury from rotating machine parts.</p> <p>Rotating machine parts may cause injury to the user or to other people working on the machine.</p> <ul style="list-style-type: none"> ➔ Switch off the machine. ➔ Switch off the tractor engine. ➔ Remove the ignition key. ➔ Wait for the machine parts to come to a complete stop.

 Danger!
<p>Risk of injury from the machine tipping over.</p> <p>If the machine lacks stability, it may tip over and injure persons in the vicinity.</p> <p>Before servicing, cleaning, lubricating and adjusting the machine or rectifying faults:</p> <ul style="list-style-type: none"> ➔ Park the machine on level and solid ground so that it cannot tip over. ➔ Apply the tractor parking brake. ➔ Switch off the tractor engine. ➔ Remove the ignition key.

 Warning!
<p>Risk of injury from emerging high-pressure hydraulic fluids.</p> <p>Emerging high-pressure fluids can penetrate the skin and cause serious injuries.</p> <ul style="list-style-type: none"> ➔ Seek immediate medical help in the event of injury. Risk of infection! ➔ Inspect the hydraulic hose lines before each use and replace all lines showing signs of damage or ageing.

Machine description

3 Machine description

The DM 306 TL disc mower is used to cut stalks that grow at ground level. It is compatible with category II and III tractor three-point attachments as standard.

The mower unit is suspended at its centre of gravity on a lifting arm, such that it can oscillate. The machine can be parked in either the working position or transport position.

3.1 Product features

Feature	DM 306 TL	DM 306 TL-KC	DM 306 TL-RC
Towing bracket for category II and III three-point attachments	X	X	X
The machine can be parked in the transport position or working position	X	X	X
Drive by means of an angle drive and PTO shaft	X	X	X
Feeder drum at the sides of the cutter bar	X	X	X
driveGUARD ³	X	X	X
TurboLift system ²	X	X	X
Impact guard ¹	X	X	X
PTO speed: 1000 rpm	X	X	X
PTO speed: 540 rpm	X	X	X
ComfortChange ⁴	(X)	(X)	(X)
Conditioners		X	X

- 1) Allows the machine to give way when encountering an obstacle.
- 2) Hydropneumatic mower suspension to adapt the machine's ground pressure to the equipment and operating conditions. Subsequently, the term "ground pressure" refers to the TurboLift system.
- 3) Overload protection system for the cutter bar that sits on the mower discs.
- 4) Subsequently referred to as the "quick-change blade system". The term "quick-change blade system" indicates the procedural differences from those for machines with bolted cutter blades.

3.2 Notices on the machine

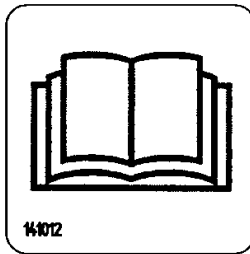

Fig. 16 Storage of the operating instructions

The adhesive notice indicates where to find the operating instructions, special tool and any other enclosed documents, and where these should be stored.

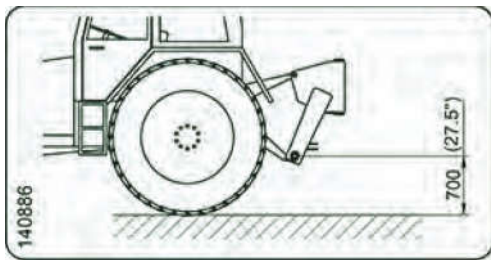

Fig. 17 Lower link height

The adhesive notice indicates how high the lower links must be set during operation.

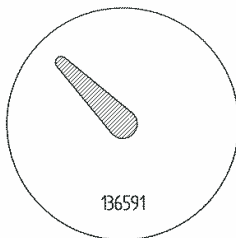

Fig. 18 Balancing pressure indicator

The adhesive notice on the pressure gauge of the TurboLift system indicates the default balancing pressure.

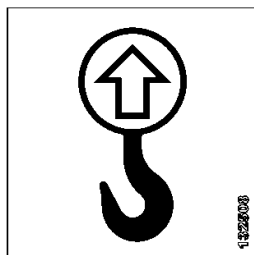

Fig. 19 Lifting point

The adhesive notice indicates an attachment point for a crane.

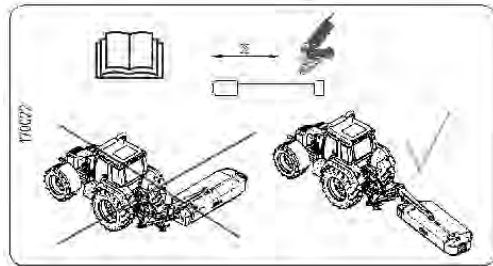

Fig. 20 Shortening the PTO shaft

The adhesive notice contains information about shortening the PTO shaft:

- Positioning the machine correctly in relation to the tractor, and
- reference to the operating instructions.

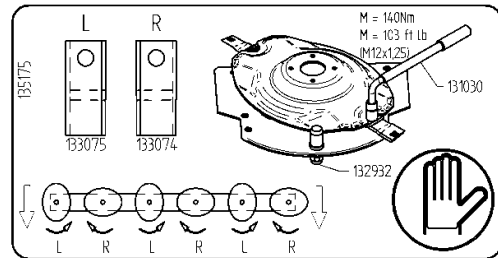

Fig. 21 Simple mower discs

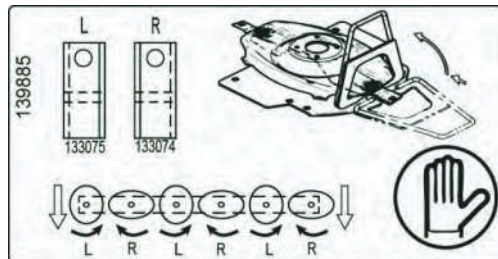

Fig. 22 Mower discs with the quick-change blade system

The adhesive notice indicates:

- The number of mower discs and the direction in which they rotate,
- the order number for the left and right cutter blade,
- that protective gloves must be worn,
- blade replacement using the special tool provided
- the order numbers for the special tool.

Machine description

For DM 306 TL-KC model:

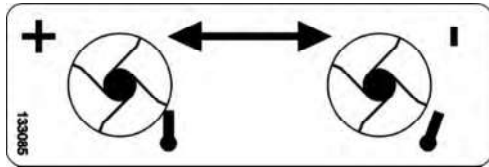

Fig. 23 Adjusting the KC comb

The adhesive notice indicates the KC comb adjustment.

3.3 Special equipment

The following special equipment is available for the machine. This can be ordered from your dealer.

Special equipment	DM 306 TL	DM 306 TL-KC	DM 306 TL-RC
Anti-wear skid ¹	X	X	X
W240-1 ³ / ₈ " articulated fork	X	X	X
W240-8x32x38 articulated fork	X	X	X
Left-hand swath disc	X		
Right-hand swath disc	X		
Mower disc with conveyor vanes		X	X
Spreader		X	

- 1) The anti-wear skid is used to set a higher cutting height and provides protection against wear on sandy or stony ground. At least two anti-wear skids are required for each cutter bar, and up to six can be attached (one per mower disc).

3.4 Machine components

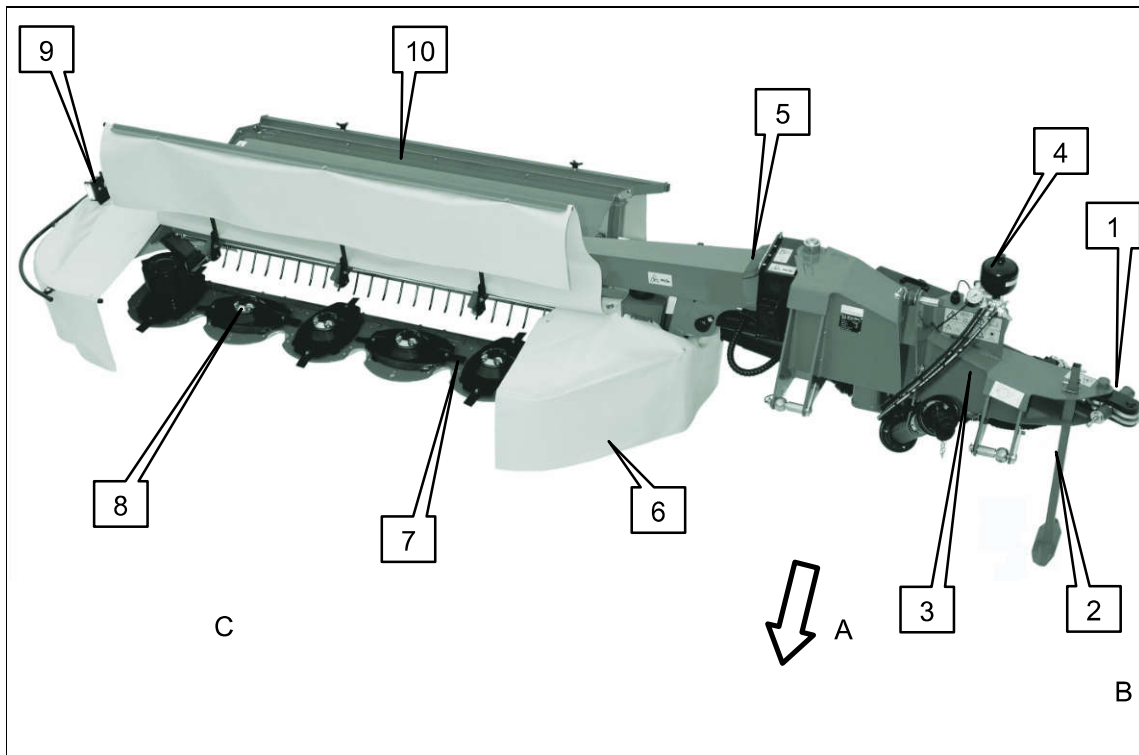

Fig. 24 Machine components

- 1 *Impact guard*
- 2 *Support leg*
- 3 *Towing bracket*
- 4 *TurboLift system*
- 5 *Lifting arm*
- 6 *Protective equipment/protective cover*
- 7 *Cutter bar*
- 8 *Mower discs*
- 9 *Lights*
- 10 *Conditioner (only for KC and RC)*

Directional data

- A *Direction of travel*
- B *left*
- C *right*

Specifications

4 Specifications

4.1 Machine data

General	DM 306 TL	DM 306 TL-KC	DM 306 TL-RC
Power requirement KW/hp	55/77	84/115	84/115
PTO stub shaft speed in rpm	540/1000		
PTO stub	1 3/8" (6t)		
Required hydraulic connections	1 x SA and 1 x DA		
Max. permitted hydraulic pressure in bar	210		
Lighting connection	7-pin socket		
Mounting Cat.	II/III		
Weight			
Weight (kg)	880	1170	1210
Dimensions			
Transport width (m)	2,3		
Transport length (m)	4,65		
Working width (m)	3,0		
Mower discs			
Number of mower discs	6		
Blades per mower disc	2		
Cutting circle (mm)	614		

4.2 Noise information

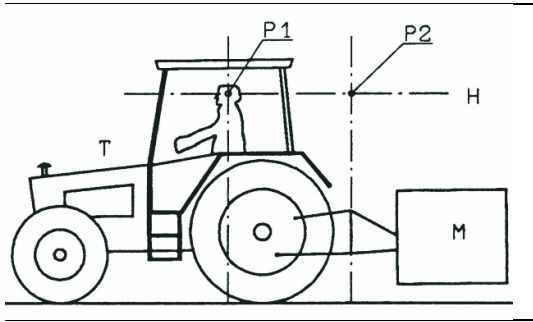

Fig. 25 Test setup

- T* Tractor
M Machine
P 1 Microphone, point 1
P 2 Microphone, point 2
H Horizontal plane

Noise level measurement on the tractor without machine

Position	Window	
	shut	open
P 1	68.2 dB (A)	72.2 dB (A)
P 2	82.2 dB (A)	84.3 dB (A)

Noise level measurement on tractor with machine

Position	Window	
	shut	open
P 1	72.1 dB (A)	86.1 dB (A)
P 2	101.1 dB (A)	102.1 dB (A)

Measurement according to DIN EN ISO 4254-1, Annex B.

Setup with tine-rotor conditioners or roller conditioners does not affect noise emissions.



Caution!

Risk of personal injury from noise caused by the machine.

When the machine is being operated, noise pollution is > 70 dB (A). This may lead to hearing damage.

- ➔ Wear hearing protection when working with the tractor cab open.

To calculate the actual noise pollution for users, a corresponding sound level measure is required on-site on the vehicle that is being used. For new vehicles, this value can also be taken from the vehicle registration (vehicle documents) if required.

Specifications

4.3 Axle loads, gross weight and minimum ballast required

The front axle of the tractor must always be loaded with at least 20% of the empty weight.

To ensure compliance with the permissible axle loads and gross weight as well as with the steerability of the tractor-machine combination, make the following calculations.

Calculation of minimum ballast required on the front axle:

$$I_{Fmin} = \frac{[I_R \times (c + d)] - (T_F \times b) + (0.2 \times T_E \times b)}{a + b}$$

Calculation of actual front axle load:

$$T_{Ftat} = \frac{[I_F \times (a + b)] + (T_F \times b) - [I_R \times (c + d)]}{a + b}$$

Calculation of actual gross weight:

$$I_{tat} = I_F + T_E + I_R$$

Calculation of actual rear axle load:

$$T_{Rtat} = I_{tat} - T_{Ftat}$$

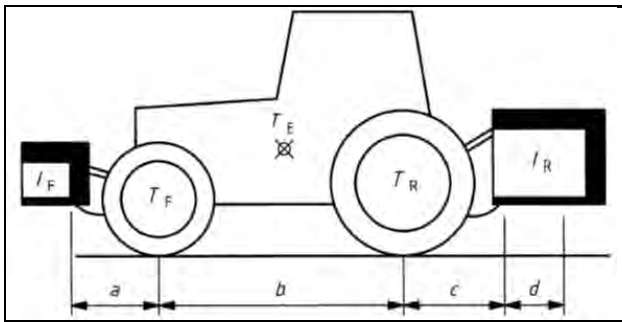

Fig. 26 for calculating required parameters

	Unit	Explanation	
T_E	[kg]	Empty weight of tractor	❶
T_F	[kg]	Front axle load of empty tractor	❶
T_R	[kg]	Rear axle load of empty tractor	❶
I_R	[kg]	Gross weight of rear-mounted attachment/rear-mounted ballast of towed machine: I_R = bearing load	❷
I_F	[kg]	Total weight of front-mounted attachment/front ballast	❷
a	[m]	Distance between centre of gravity of front-mounted attachment/front ballast and centre of front axle	❷ ❸
b	[m]	Tractor wheel base	❶ ❸
c	[m]	Distance between centre of rear axle and centre of lower link balls	❶ ❸
d	[m]	Distance between centre of lower link balls and centre of gravity of rear-mounted attachment/rear-mounted ballast of towed machine: $d = 0$	❸

- ❶ See tractor operating instructions
- ❷ See front-mounted attachment operating instructions
- ❸ Dimensions
- ❹ See type plate

5 Before initial operation

5.1 Assembling the machine

The machine is partially assembled when it is delivered from the factory. Your dealer will receive a set of assembly instructions with the machine and is responsible for making sure the machine is assembled correctly.



Warning!

Risk of injury as a result of incorrect assembly

Improper assembly may lead to malfunctions and damage to the machine, which could result in injury to persons.

- ➔ The machine must only be assembled by trained personnel or specialist workshops in accordance with the assembly instructions.
- ➔ Contact your dealer if the machine needs to be assembled or disassembled.

5.2 Adjusting the PTO shaft



Warning!

Risk of injury as a result of incorrect installation

Incorrect installation of the PTO shaft may cause personal injury and material damage.

- ➔ Only PTO shafts which have been approved by the manufacturer may be used for this machine.
- ➔ Follow the PTO shaft manufacturer's operating instructions.
- ➔ Before each use, check that the PTO shaft is fitted and functioning correctly and that the protection devices are complete.



Important!

Risk of material damage as a result of damage to the PTO shaft

The PTO shaft may be damaged if:

- The PTO shaft is too long or too short,
 - The curved barrel cover is too small,
 - The drive speed is too high, or
 - It has been inadequately maintained.
- ➔ Check the length and barrel cover of the PTO shaft.
 - ➔ Always take the maximum permissible drive speed into account.
 - ➔ Follow the PTO shaft manufacturer's operating instructions.

As supplied, the PTO shaft is the maximum length. It is therefore possible to adjust the PTO shaft on different tractors.

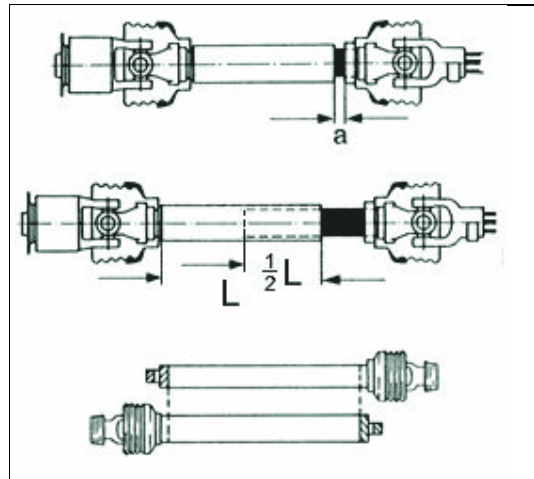

Fig. 27 PTO shaft minimum measurements

The length of the PTO shaft must be adjusted so that:

- The profile tubes overlap by at least half their length L in the longest operating state.
- In the shortest operating state, the safety distance to the yoke end of the universal joint is still $a = 25 \text{ mm}$.

Before initial operation

Shortening the PTO shaft

- ➔ Establish the shortest operating distance between the tractor and the machine. This is achieved if:
 1. The PTO shaft connections of the tractor and machine are at the same height and



Fig. 28 PTO shaft connections at the same height

2. The machine is pivoted in the transport position behind the tractor.



Fig. 29 Transport position

- ➔ Pull the two halves of the PTO shaft apart.
- ➔ Attach each half to the corresponding connection.
- ➔ Hold the two halves of the PTO shaft side by side.

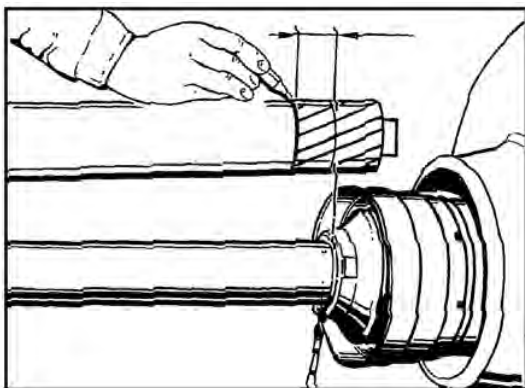

Fig. 30 Mark the measurement

- ➔ On the outer protective tube, mark a measurement of 25 mm from the edge of the inner protective tube.
- ➔ Shorten the outer protective tube.
- ➔ Shorten the inner protective tube and both profile tubes by the same amount.
- ➔ Pay particular attention when shortening plastic-coated profile tubes to make sure that the cut surface does not get too hot. If it gets too hot, the coating could burn and the PTO shaft could then seize during use.
- ➔ Deburr and clean the cut ends.
- ➔ Grease the inner profile tube.
- ➔ Check the profile tube overlap at the longest operating distance. It must be at least half of the length when pushed together.

6 Attachment to the tractor



Warning!

Risk of injury as a result of crushing or shearing

Coupling, raising or lowering the lower link may result in injury to anyone remaining within the area around the lower link rods.

- ➔ Do not step between the tractor and the machine when you are lifting and lowering the lower links.
- ➔ Ensure that there is no-one between the tractor and the machine.



Caution!

Risk of injury as a result of insecure fastening of the machine to the tractor

If the standardised three-point categories for tractor and machine do not match, this may result in personal injury and material damage.

- ➔ Make sure that the standardised categories match when attaching the machine to the tractor.
- ➔ Check that the securing elements on the hitch are in good condition.

6.1 Initial operation

- ➔ Check the maintenance intervals (see chapter 13 Servicing) to see when maintenance work is due and perform this work correctly.
- ➔ Check that the PTO shaft is fitted and operating correctly and that all protection devices are in place.
- ➔ Check the machine for damage. Rectify any damage.

6.2 Coupling the machine

The machine is equipped for category II and III three-point attachments as standard.

- ➔ Set the left and right tractor lower links to the same height.
- ➔ Minimise the lateral movement of the tractor lower links.

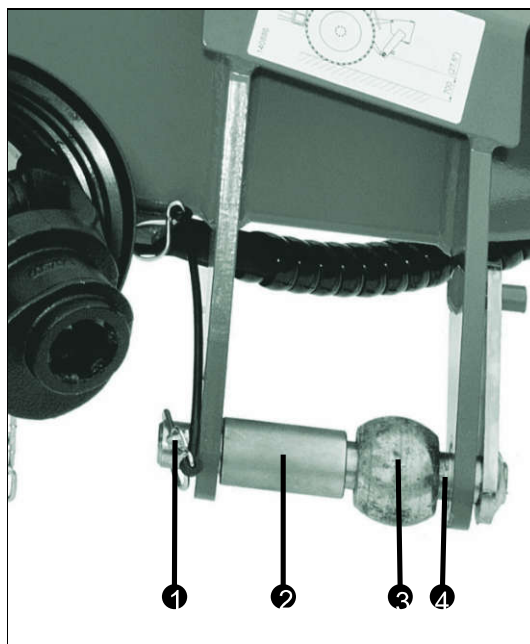
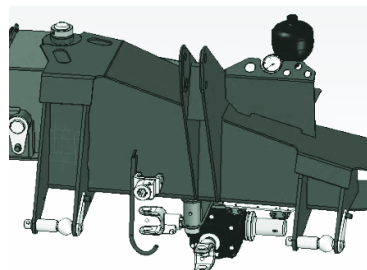

Fig. 31 Adjusting the lower links

- ➔ Release the safety cotter pin (1).
- ➔ Pull back the lower link bolt (4) until it is possible to take out the spacer (2).
- ➔ Fit the spacer (2) and lower link ball (3) in the order that corresponds to the category of your tractor's three-point attachment.

For category II A:

Both lower link balls point to the left in relation to the direction of travel



Attachment to the tractor

For category II B:

Both lower link balls point to the right in relation to the direction of travel

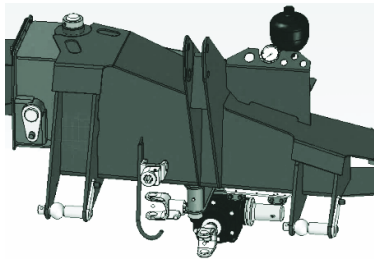

For category III A:

The right-hand lower link ball points to the right, and the left-hand lower link ball points to the left

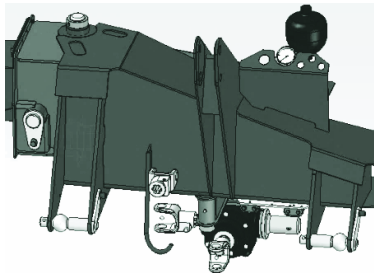

- Secure the lower link bolt (4) with the safety cotter pin (1).
- With the lower links lowered, reverse the tractor towards the machine.
- Lift the lower links until the lower link balls lie in the catch hooks.
- Check the safety devices, and engage them manually if necessary.

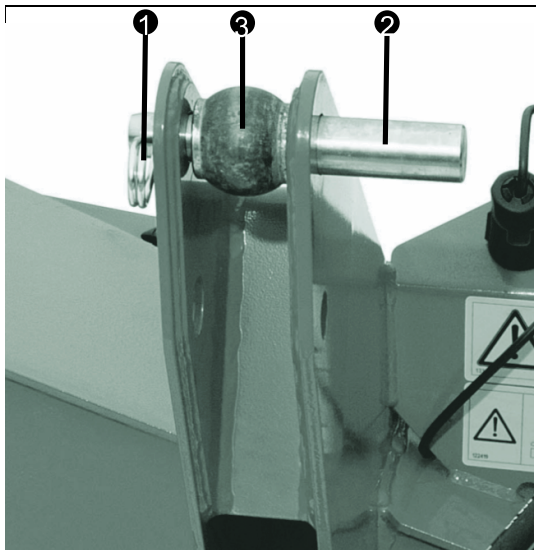

Fig. 32 Preparing the top link

- Release the safety cotter pin (1).
- Pull out the top link assembly bolt (2).

- Place the top link ball (3) on the top link assembly bolt (2).
- Slide the top link assembly bolt (2) back in.
- Secure it with the safety cotter pin (1).
- Undo the top link from the tractor and fasten it to the top link of the machine.



Note

A hydraulic top link enables the cutting height of the rear-mounted mower to be adjusted from inside the tractor.



Important!

Risk of damage to property from operating the hydraulic top link incorrectly

Significant changes to the length of the hydraulic top link can cause the PTO shaft to buckle. This can damage the gearbox.

- Check the length of the PTO shaft when using the machine.

- Lift the lower links until the weight is taken off the support leg.

Attachment to the tractor

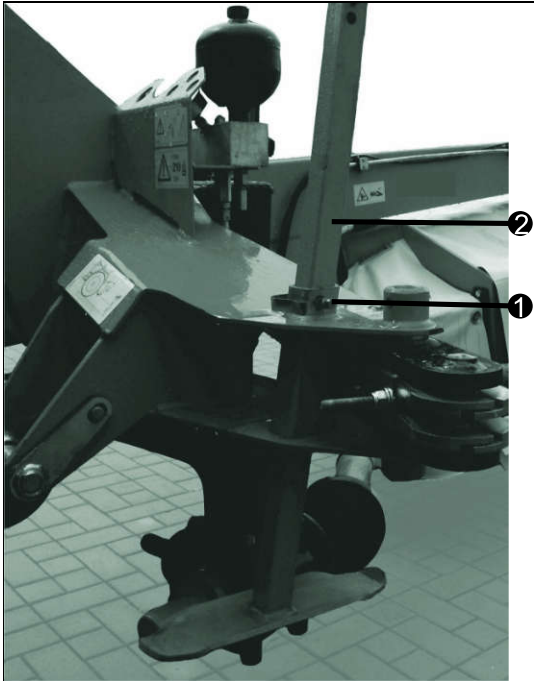

Fig. 33 Support leg raised

- ➔ Release the clip-on bolt (1).
- ➔ Pull the support leg (2) upwards.
- ➔ Secure it with the clip-on bolt (1).

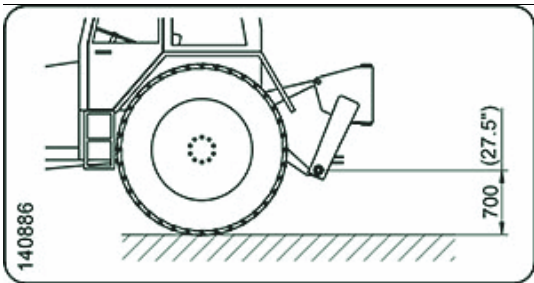

Fig. 34 Adjusting the machine frame

- ➔ Adjust the machine frame horizontally by moving the lower links to a height of 700 cm.
- ➔ Maintain this position during use of the machine.

6.3 Connecting the PTO shaft to the tractor



Caution!

Risk of injury when fitting/removing the PTO shaft

Rotating machine parts may cause personal injury and material damage.

Before you attach/detach the PTO shaft:

- ➔ Switch off the PTO shaft on the tractor.
- ➔ Switch off the tractor engine.
- ➔ Remove the ignition key.



Warning!

Risk of injury as a result of incorrect installation

Incorrect installation of the PTO shaft may cause personal injury and material damage.

- ➔ Follow the PTO shaft manufacturer's operating instructions.
- ➔ Before each use, check that the PTO shaft is fitted and functioning correctly and that the protection devices are complete.



Fig. 35 PTO shaft protection device on the tractor

Attachment to the tractor

- ➔ Check that the PTO shaft guard (1) and safety chain (2) are in place and undamaged.
- ➔ Turn the PTO shaft holder towards the frame and slide the PTO shaft onto the drive stub shaft on the tractor. You must hear the PTO shaft click into place.
- ➔ Check that it is seated securely.
- ➔ Attach the safety chain (2) to the tractor so that the protective tube cannot rotate with the PTO shaft.

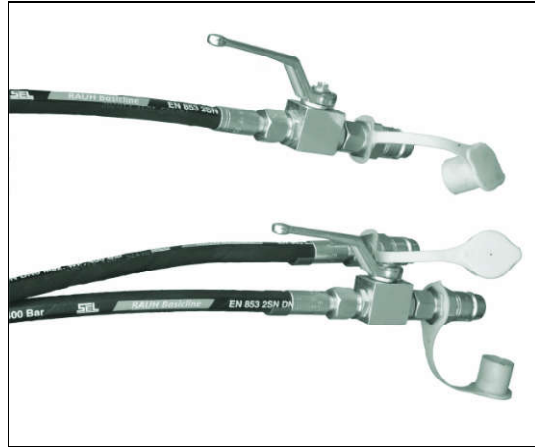



Fig. 36 Hydraulic lines of the machine

The hydraulic hoses on the machine are fitted with Kennfixx adapters.

When installing, pay attention to:

- Colour of adapter
- Plus/Minus mark

Colour	Adapter Plus	Adapter Minus
		
Red	For swinging from working position to transport position	Swing from transport to working position
Black	Headland position	

- ➔ Connect the two hydraulic hoses marked red to a double-acting control valve and the hydraulic hose marked black to a single-acting control valve with lockable floating position on the tractor. You must hear the hydraulic hoses click into place.
- ➔ Check that the hydraulic hoses are seated securely.

6.5 Connecting the lighting

- ➔ Insert the 7-pin plug for the lighting into the socket on the tractor.
- ➔ Check the function of the lighting on the machine.



Warning!

Risk of injury from accidentally moving the machine

Undesired movement of the machine as a result of incorrect use or carelessness can put people standing in the movement range of the machine at risk.

- ➔ Read the operating instructions before commissioning.
- ➔ Observe the operating instructions when using the machine.
- ➔ Check the hydraulic hose connections are correct when attaching hydraulic cylinders and motors.
- ➔ Label coupling sleeves and plugs to prevent confusion. Incorrect connections can lead to reversed operation (e.g. raising/lowering).

7 Transport position and working position

7.1 Switching the machine to transport position



Warning!

Risk of injury from rotating machine parts

Rotating machine parts may cause injury to the user or to other people working on the machine.

- Switch off the machine.
- Switch off the tractor engine.
- Remove the ignition key.
- Wait for the machine parts to come to a complete stop.



Important!

Possible material damage caused by disregarding the transport height and swivelling range.

If the machine is in the vicinity of obstacles (e.g. buildings, bridges, overhead cables), you must observe the height and swivelling range (see chapter 4 Specifications).

- Make sure that there are no obstacles in the swivelling range.



Warning!

Risk of injury as a result of raising or lowering the machine

Lifting or lowering the machine can result in injury to anyone remaining within the swivelling range of the machine.

- Make sure there is no-one within the swivelling range of the machine.



Warning!

Risk of tipping on sloping terrain

Lifting or lowering the machine on sloping terrain increases the risk of it tipping over

- Never lift the machine into the transport position at a right angle to the slope.
- Set the SA control valve to lifting.
- Lift the machine to the height limitation in the headland position.
- Swing the machine into the transport position by actuating the DA control valve.

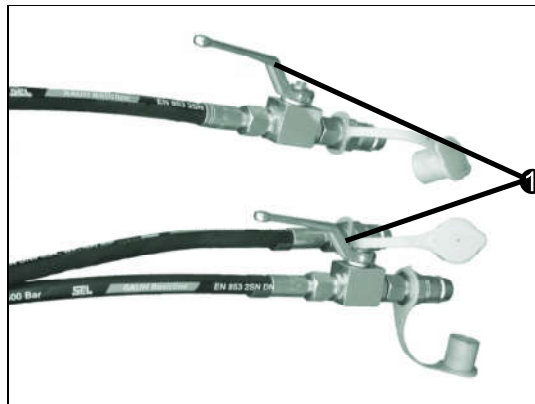

Fig. 37 Stop valve for the hydraulic line

- Close the stop valves (1).



Fig. 38 Transport position

Transport position and working position

Road travel



Warning!

Risk of injury as a result of insufficient steerability

The tractor will lose steerability if the load of the suspended machine takes too much weight off its front wheels.

- If there is insufficient weight on the front wheels of the tractor, fit ballast weights to the front of the tractor to maintain steerability (see section 4 Specifications).

- Lower the machine into the working position.



Fig. 39 Working position

7.2 Switching the machine to working position

- Switch off the tractor engine.
- Open the stop valves on the hydraulic lines.
- Start the tractor engine.



Warning!

Risk of injury as a result of raising or lowering the machine

Lifting or lowering the machine can result in injury to anyone remaining within the swivelling range of the machine.

- Make sure there is no-one within the swivelling range of the machine.
- Set the SA control valve to lifting.
- Lift the machine until it reaches the height limitation in the headland position.
- Swing the machine round to the working side of the tractor by actuating the DA control valve.
- Set the SA control valve to its floating position.

8 Using the machine



Warning!

Risk of injury due to loose cutter blade holders.

Coming into contact with foreign objects may damage the cutter blade holders and cause them to become loose. This may lead to cutter blades being ejected during operation, resulting in injury.

- Check that the cutter blade holders are securely in place and are not damaged.
- Replace any loose or damaged cutter blade holders.



Warning!

Risk of injury from rotating machine parts.

Rotating machine parts may cause injury to the user or to other people working on the machine.

- Switch the machine off immediately if people enter the hazard area or approach the machine.
- Instruct everyone to leave the hazard area.



Important!

Risk of material damage from an excessively high drive speed

Excessive drive speed may result in damage to the machine.

- Make sure that the maximum permitted drive speed of 540 or 1000 rpm is not exceeded.
- Set the SA control valve to its floating position.
- Switch on the PTO shaft.
- Adjust the drive speed and maintain it while using the machine.



Fig. 40 Headland position

- For turning at the end of the field, set the SA control valve to lifting.
- Lift the machine into the headland position.
- After turning, lower the machine back into the working position by setting the SA control valve to the floating position.

9 Settings



Warning!

Risk of injury from moving machine parts.

Unwanted movement of the machine may occur in the course of adjustment work. Unless otherwise prescribed in these operating instructions, proceed as follows:

- ➔ Apply the tractor parking brake.
- ➔ Switch off the tractor engine.
- ➔ Remove the ignition key.
- ➔ Secure the machine and tractor against rolling away.

9.1 Adjusting cutting height

The cutting height is measured from the centre of the cutter blade to the ground. The machine should be parked on a level surface in the working position for this.

- ➔ By altering the length of the top link, you can adjust the cutting height.

Lengthen Higher cutting height

Shorten Lower cutting height



Important!

Risk of damage to property from operating the hydraulic top link incorrectly

Significant changes to the length of the hydraulic top link can cause the PTO shaft to buckle. This can damage the gearbox.

- ➔ Make sure that the minimum clearance of 25 mm is maintained for the length of the PTO shaft.



Note

A cutting height that is too low can damage the sward and contaminate the forage. As a result, both the average annual harvest and the forage quality decrease.

9.2 Adjusting the ground pressure



Danger!

Risk of explosion due to the gas-pressurised TurboLift system

The accumulator (pressure container) in the TurboLift system is pressurised with gas. There is therefore a risk of injury from explosion when working on the TurboLift system.

- ➔ Follow the HYDAC operating instructions that accompany the other documentation (see documents provided by HYDAC).
- ➔ HYDAC request that repairs only be carried out by a qualified professional.



Note

The TurboLift system requires no maintenance.

The pressure relief valve in the TurboLift system preselects the ground pressure. The pressure may need to be adjusted depending on the nature of the soil and travelling speed.

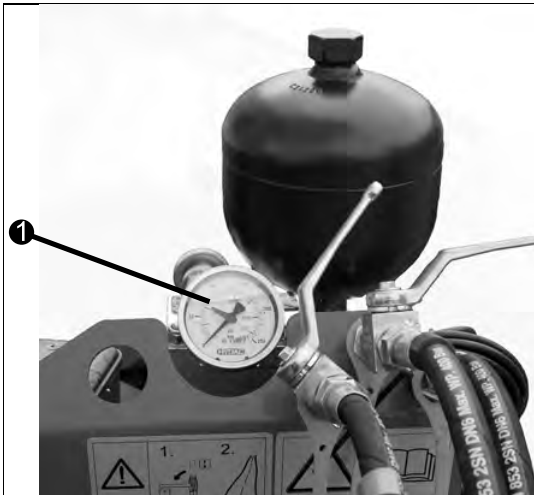

Fig. 41 TurboLift system accumulator

The label on the pressure gauge indicates the factory default value.

	DM 306 TL	DM 306 TL-KC	DM 306 TL-RC
Balancing pressure (bar)	55	70	75
Initial accumulator pressure (bar)	35	35	35



Important!

Risk of material damage if the pressure in the TurboLift system is too high.

Adjusting the TurboLift system on a machine that has been lifted at the headland can lead to high pressure. This can damage the sealing rings of the control valve.

→ Only make this adjustment when the machine is in the working position.

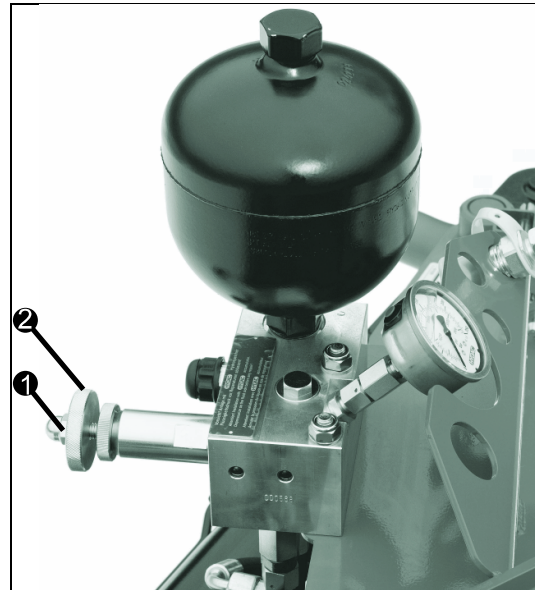

Fig. 42 Pressure relief valve

→ Undo the lock nut (1).

→ Either screw in or unscrew the pressure bolt (2) to set the required pressure.

Screw in Pressure is increased → increased suspension

Unscrew Pressure is decreased → decreased suspension

→ Tighten the lock nut (1).

The new suspension pressure is activated the next time the machine is raised or lowered.

9.3 Adjusting the tine rotor conditioner (KC)

9.3.1 Adjusting the conditioner intensity

You can set the conditioner intensity can by adjusting the comb. You can adjust the comb incline using the adjusting bar. There are four settings for the intensity.

Settings

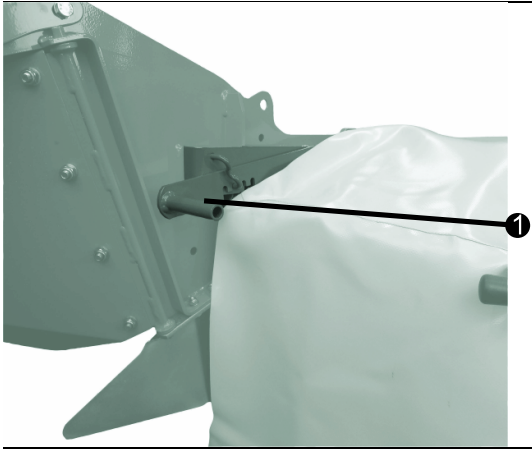
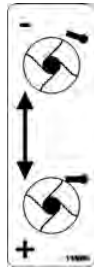

Fig. 43 KC adjusting bar

→ Move the adjusting bar (1) to adjust the conditioner intensity.

- Backwards → Reduced intensity

+ Forwards → Greater intensity



9.3.2 Adjusting the swath guiding assembly

You can set the swath width using the swath boards. It is infinitely variable.

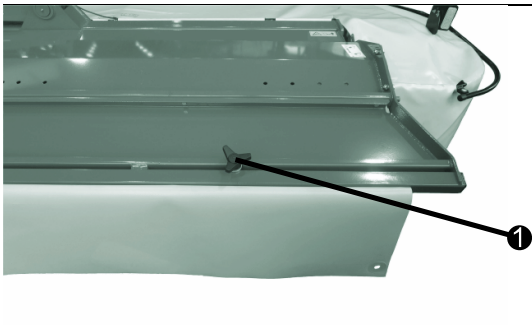

Fig. 44 KC swath guiding assembly

→ Undo the three-arm knob(1).

→ Slide the three-arm knob (1) and the swath board to the required width, and lock in position using the three-arm knob.

9.4 Adjusting conditioners with rubber rollers (RC)

9.4.1 Adjusting the conditioner intensity

The clearance between both rubber rollers determines the intensity of the conditioner – infeed and ejection of the crop. It can be adjusted using the two adjustment screws on the left- and right-hand side of the roller conditioner.



Fig. 45 Clearance between rollers

The clearance between the rubber rollers is measured between the profile on the one roller and the groove on the other. The clearance should be between 5 and 7 mm.

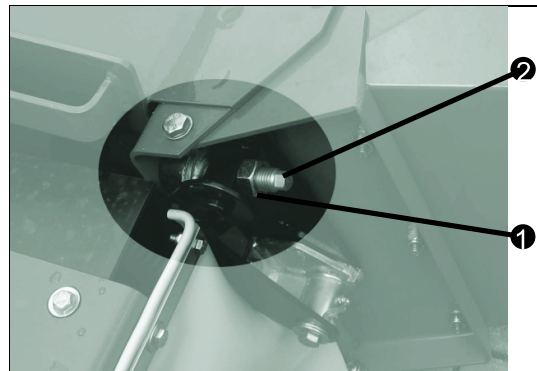

Fig. 46 Adjusting the RC conditioner intensity, left

- ➔ Undo the lock nut (1).
- ➔ Set the adjusting bolts (2) to the required roller clearance.

Clockwise Smaller clearance
 Anticlockwise Greater clearance

- ➔ Tighten the lock nut (1).
- ➔ Set both sides equally.

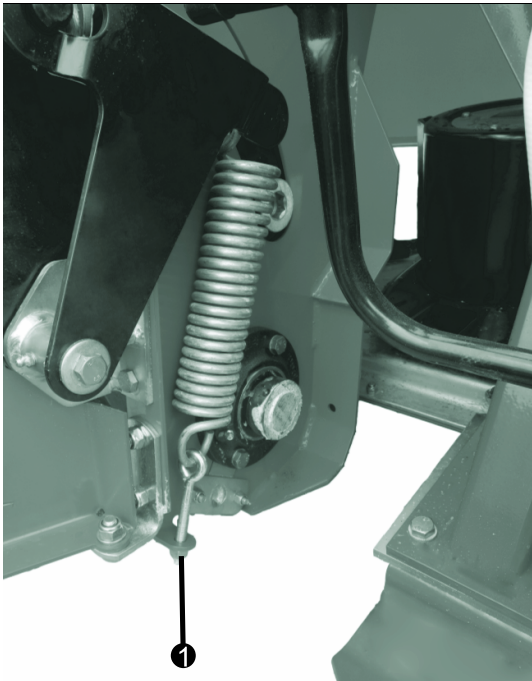

Fig. 47 Adjusting the RC conditioner intensity

- ➔ Turn the nut (1) to alter the tension of the uppermost rubber roller spring.

Clockwise Larger projection as in Fig. 48→ greater spring preload

Anticlockwise Smaller projection as in Fig. 48→ lower spring preload

- ➔ Set both sides equally.

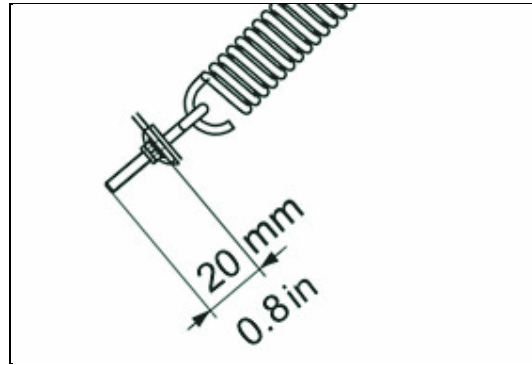

Fig. 48 Factory setting

The factory setting for the projection of the nut and thread is 20 mm.

9.4.2 Adjusting the swath guiding assembly

The swath width can be adjusted in three stages.

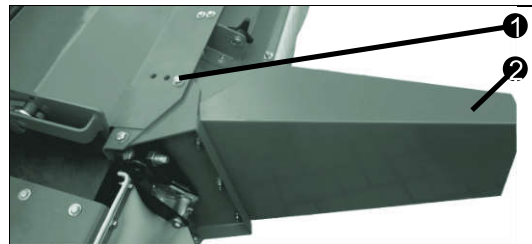

Fig. 49 RC swath guiding assembly

- ➔ Undo the bolt (1).
- ➔ Slide the swath board (2) to the required width and lock it in place with the bolt.

Optional functions

10 Optional functions

Note

Special equipment must be fitted in accordance with the supplied assembly instructions.

10.1 Greater cutting height using anti-wear skids

Note

One anti-wear skid per mower disc is recommended (see section 3.3 Special equipment).

Adjusting the cutting height when using an anti-wear skid:

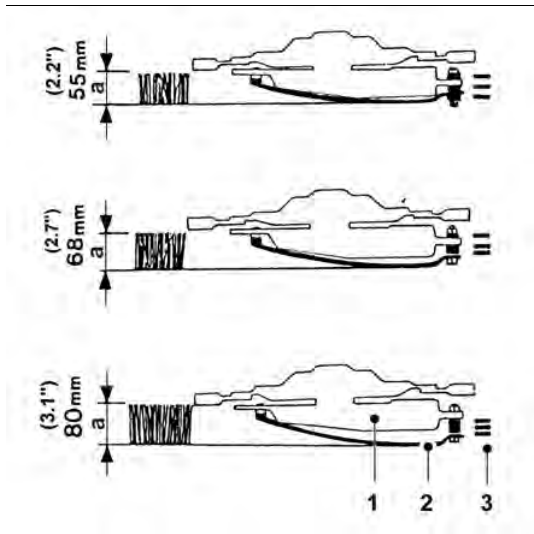

Fig. 50 Cutting heights when using an anti-wear skid

- ➔ Undo the anti-wear skid.
- ➔ Arrange the spacers (3) between the anti-wear skid (2) and the mower disc (1) according to the cutting height required.

Cutting height:

- a = 55 mm Low
- a = 68 mm Medium
- a = 80 mm High

- ➔ Bolt and tighten the anti-wear skid.

10.2 Swath guiding disc

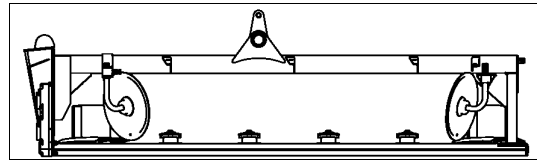

Fig. 51 Swath guiding discs installed

- ➔ Loosen the bolt.
- ➔ Turn the swath disc to the required position and lock it in place with the bolt.

Note

Machines without conditioners can be retrofitted with swath guiding discs (see section 3.3 Special equipment).

10.3 KC spreader

Changing the angle of the guide plate can affect spreading.

- ➔ Loosen the guide plate bolt.
- ➔ Turn the guide plate in the direction required and screw the bolt up tightly.

Note

The KC can be retrofitted with the spreader (see section 3.3 Special equipment).

11 Machine storage



Danger!

Risk of injury from the machine slipping, lowering or tipping over

If the machine slips, lowers or tips over, anyone standing near it may be put at risk.

- Park the machine on level and firm ground.
- Ensure the machine is sufficiently stable.

- Move the SA and DA control valve to the floating position.



Danger!

Risk of injury from running-on machine parts

The work tools on the machine may continue to run after the drive has been switched off, causing personal injury.

- Wait until all machine parts have stopped rotating.
- Approach the work tools only when they are stationary.

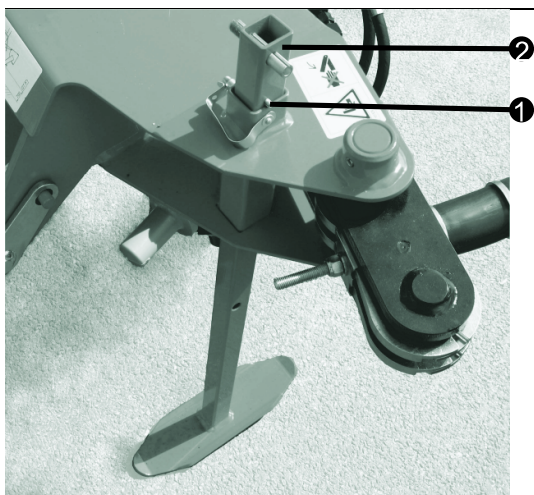

Fig. 52 Support leg lowered

- Release the clip-on bolt (1).

- Slide the support leg (2) down as far as the second hole.
- Secure the support leg (2) with the clip-on bolt (1).
- Lower the lower links of the tractor until the machine rests on the support leg.
- Remove the PTO shaft from the tractor.

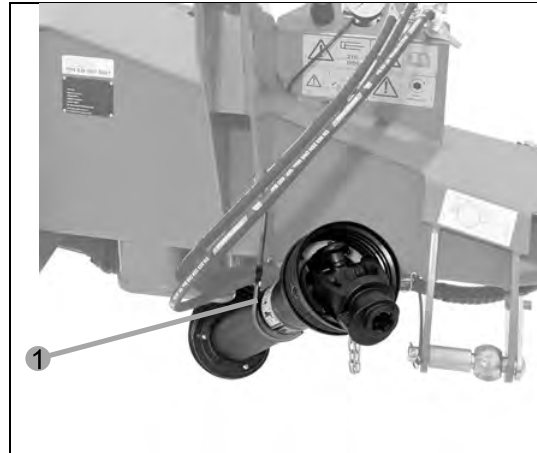

Fig. 53 PTO shaft holder

- Place the PTO shaft on the PTO shaft holder (1).

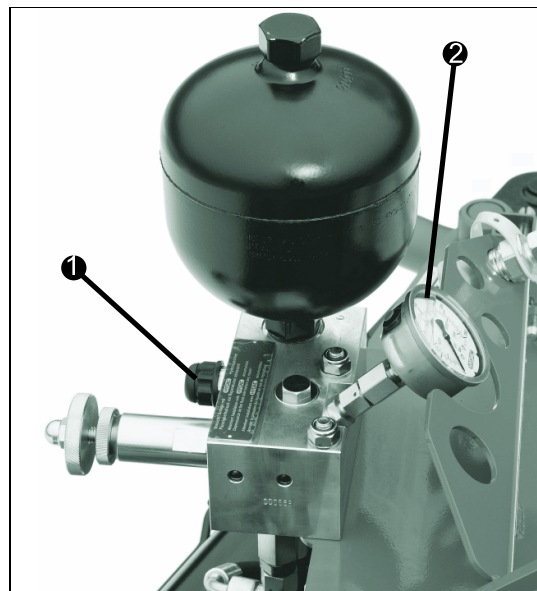

Fig. 54 Releasing the pressure

- Release the TurboLift system pressure by pressing the push-button (1).

Machine storage

- Check the pressure on the pressure gauge (2). The needle must be at 0.

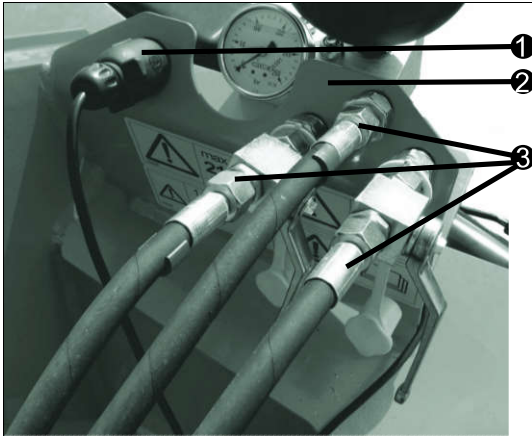



Fig. 55 Holder on the hitch block

- Unplug the 7-pin plug (1) of the lighting cable.
- Insert the plug into the holder (2) on the machine.
- Make sure that the SA and DA control valves are in the floating position.
- Remove the hydraulic hoses (3).
- Insert the hydraulic hoses (3) into the holder (2) on the machine.
- Release the top link catch hook.
- Detach the top link of the tractor from the machine.
- Release the catch hooks of the lower links.
- Lower the lower links until the lower link balls on the machine are released and the tractor can continue to be driven safely.

Recommendations for longer service life

- Clean the machine (see section 13.3 Cleaning).
- Lubricate all lubricating points (see section 13.12 Lubrication instruction).
- Allow the machine to run briefly in working position.
- Check the machine for wear and damage and have repairs carried out as necessary.
- Remove any rust.
- Repair any paint damage.
- Spray the machine with anti-corrosion oil.
- To prevent the machine from being exposed to corrosive substances (fertiliser, manure gases or salty sea air), keep it in a dry, weatherproof place.
- Store the machine in transport position.

12 Rectifying faults



Warning!

Risk of injury from moving machine parts.

Any machine repair work must only be carried out when the machine is not running.

- ➔ Apply the tractor parking brake.
- ➔ Switch off the tractor engine.
- ➔ Remove the ignition key.
- ➔ If maintenance work is being carried out on the raised machine, use suitable support elements to stop the machine lowering and tipping over.



Important!

Risk of material damage due to use of non-original spare parts.

Spare parts that do not fulfil the requirements reduce the machine's safety, reliability and performance.

➔ Use only original spare parts. Information on these can be found in the spare parts catalogue or obtained from your specialist workshop.

Fault	Possible causes	Remedy
Impact guard is triggered too late	Elastomer spring has been adjusted incorrectly	Correct the spring adjustment (see section 12.2 Adjusting the impact guard).
Impact guard is triggered too often/prematurely	The mower unit's ground pressure is too high (e.g. it has been adjusted incorrectly or is the result of a loss of pressure in the TurboLift system)	Adjust the ground pressure (see section 9.2 Adjusting the ground pressure). Observe the ground pressure indicated on the pressure gauge. If the ground pressure has to be readjusted each time the machine is lowered, contact your specialist workshop.
	Elastomer spring has been adjusted incorrectly or is worn	Correct the spring adjustment (see section 12.2 Adjusting the impact guard), or have the spring replaced at your specialist workshop.
Irregular cutting pattern	Rotational speed is too high or too low	Correct the rotational speed (max. permitted 540 rpm or 1000 rpm).
	Slip clutch friction linings worn	Replace the friction linings (see the PTO-shaft manufacturer's operating instructions).
	Cutter blades worn	Replace the cutter blades (see section 13.9 Cutter blades).
	driveGUARD has been triggered	Replace the driveGUARD element that has been triggered (see section 12.3 Replacing the driveGUARD).
Control valves actuated but the machine does not appear to react	Stop valve on the hydraulic line closed	Open the stop valve.
	Hydraulic plug does not open properly or has been pulled out of the hydraulic socket	Test the hydraulic plug and engage it fully. Replace it if necessary.

Rectifying faults

Fault	Possible causes	Remedy								
Swath too wide/narrow	Swath guiding assembly has been adjusted incorrectly	Adjust the swath guiding assembly correctly. <table border="0"> <tr> <td>Model</td> <td>See section</td> </tr> <tr> <td>DM 306 TL equipped with swath discs</td> <td>10.2 Swath guiding disc</td> </tr> <tr> <td>DM 306 TL-KC</td> <td>9.3.2 Adjusting the swath guiding assembly</td> </tr> <tr> <td>DM 306 TL-RC</td> <td>9.3.2 The factory setting for the projection of the nut and thread is 20 mm. Adjusting the swath guiding assembly</td> </tr> </table>	Model	See section	DM 306 TL equipped with swath discs	10.2 Swath guiding disc	DM 306 TL-KC	9.3.2 Adjusting the swath guiding assembly	DM 306 TL-RC	9.3.2 The factory setting for the projection of the nut and thread is 20 mm. Adjusting the swath guiding assembly
Model	See section									
DM 306 TL equipped with swath discs	10.2 Swath guiding disc									
DM 306 TL-KC	9.3.2 Adjusting the swath guiding assembly									
DM 306 TL-RC	9.3.2 The factory setting for the projection of the nut and thread is 20 mm. Adjusting the swath guiding assembly									
There appears to be no conditioning	The conditioner's overload protection system has been triggered	Replace the shear bolt (see section 12.4 Overload protection system for the conditioner).								
Vibrations on the mower unit	Faulty or damaged cutter blades	Replace the faulty or damaged cutter blades in pairs (see section 13.9 Cutter blades).								
	Mower discs are contaminated	Clean the contaminated mower discs.								
	Faulty or damaged KC tines	Replace any faulty or damaged tines. If necessary, have the KC rotor rebalanced by your specialist retailer.								
Cutter bar is making a clanking noise	Cutter blades are knocking against each other	Check for any damage to the driveGUARD element and that it has been installed correctly (see section 12.3 Replacing the driveGUARD).								
		Have the cutter bar balanced at a specialist workshop.								
		Check whether the correct cutter blades have been installed.								

→ Contact a specialist workshop immediately in the event of any other malfunctions.

12.1 If the machine runs over an obstacle

- Switch off the machine.
- Switch off the tractor engine.
- Remove the ignition key.
- Check the cutter blades for damage.
- Replace any damaged cutter blades.

- Check that the cutter blade holders are securely in place and are not damaged.
- Replace any loose or damaged cutter blade holders.
- Check the rest of the machine for damage.
- If you discover further damage, replace the affected parts or have them repaired by a specialist workshop.
- To re-engage the impact guard, reverse the tractor.

12.2 Adjusting the impact guard



Important!

Risk of material damage from incorrect adjustment of the impact guard

Damage to the machine can occur if the impact guard is triggered too soon or too late.

- ➔ Adjust the force with which the impact guard is released such that there is enough spring load to release it.

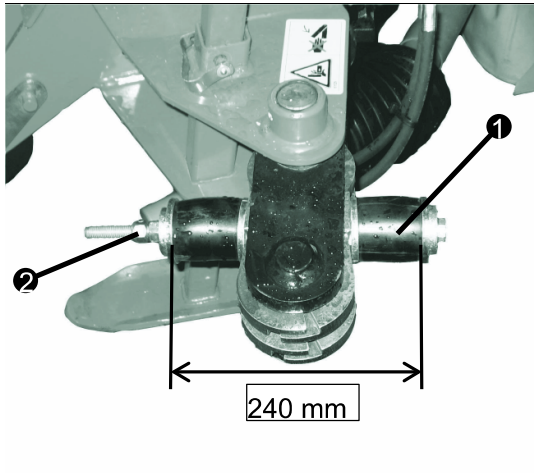

Fig. 56 Impact guard elastomer spring

- ➔ The standard length of the impact guard elastomer spring (1) is 240 mm.
- ➔ Where necessary, adjust the force with which the elastomer spring (1) is released by turning the nut (2).

Clockwise Greater release force
Counter-clockwise Smaller release force

12.3 Replacing the driveGUARD

The machine drive is protected by driveGUARD – an element that connects the drive flange and the mower disc. The driveGUARD element is triggered if the mower disc is blocked by foreign objects.

Result: The mower disc turns freely, power to the drive is interrupted and damage prevented.

A driveGUARD element that has been triggered can be identified by:

- A poor cutting pattern or no visible cut on the forage (creation of stripes) at the cutting position of the affected mower disc,
- the mower disc is not situated at a 90° angle to the adjacent mower discs and can be turned manually.

The driveGUARD element can be replaced on site.



Danger!

Risk of injury from running-on machine parts!

The work tools on the machine may continue to run after the drive has been switched off.

- ➔ Wait until all machine parts have stopped rotating.
- ➔ Approach the work tools only when they are stationary.



Caution!

Risk of injury from sharp edges and burrs!

There is a risk of injury and cutting yourself when replacing parts with sharp edges.

- ➔ Wear protective gloves.



Important!

Risk of material damage to cutter blades and cutter bar!

Incorrect installation may lead to the cutter bar losing its synchronisation. The cutter blades could then hit each other.

- ➔ Always replace the driveGUARD elements individually.
- ➔ If several mower discs have been affected, replace a single driveGUARD element completely first. Only then unbolt the next element.

Rectifying faults

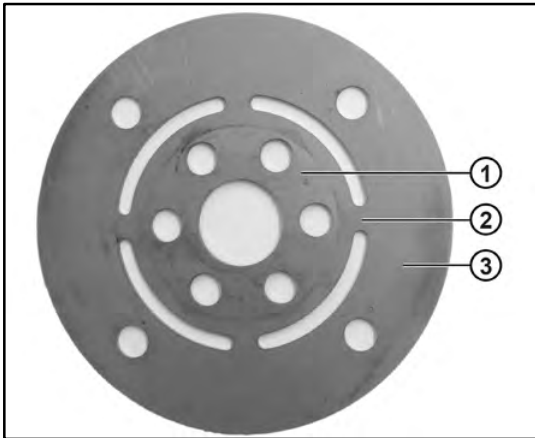

Fig. 57 driveGUARD element

- 1 Connection to gearbox unit
- 2 Shearing areas
- 3 Connection to mower disc

Required tools:

- Stop pins (tool box)
- Socket spanner
- For mower discs with feed drum:
Suitable extension for socket spanner
- Torque wrench

12.3.1 Preparatory work

- ➔ Park the machine on a level surface.
- ➔ Switch off the PTO shaft on the tractor.
- ➔ Switch off the tractor engine.
- ➔ Remove the ignition key.
- ➔ Open the guard on the respective mower unit.
- ➔ Locate the driveGUARD element that has been triggered.

The procedure required for replacing the driveGUARD element differs depending on the mower disc model.

12.3.2 Mower disc without feed drum

Removal

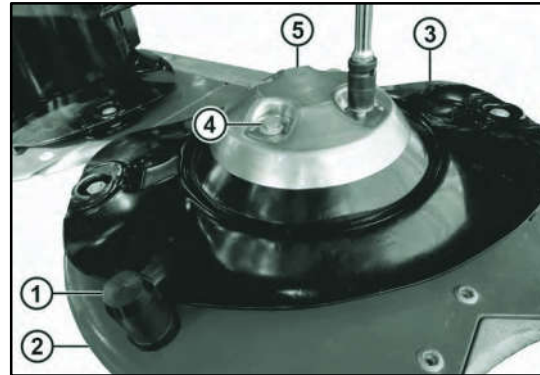

Fig. 58 Stop pin in stone guard disc

- ➔ Insert the stop pin (1) into the stone guard disc (2) of the respective mower disc (3).
- ➔ Rotate the mower disc to the stop pin to prevent the mower disc from rotating further.
- ➔ Release the 4 screws (4) from the cover (5) of the mower disc.
- ➔ Remove the cover.



Fig. 59 Triggered driveGUARD element

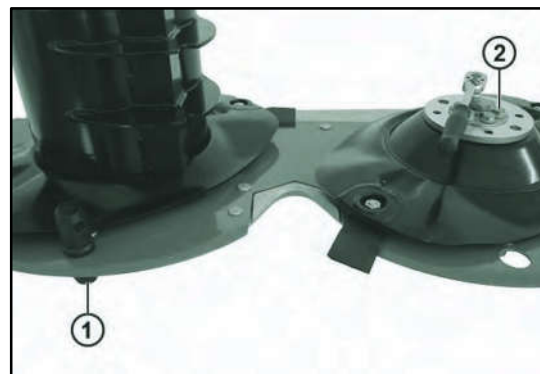

Fig. 60 Release the inner bolts

- ➔ Insert the stop pin (1) into the adjacent mower disc.
- ➔ Release the 6 inner bolts (2) on the driveGUARD element.
- ➔ Carefully remove all parts of the released driveGUARD element.

Installation

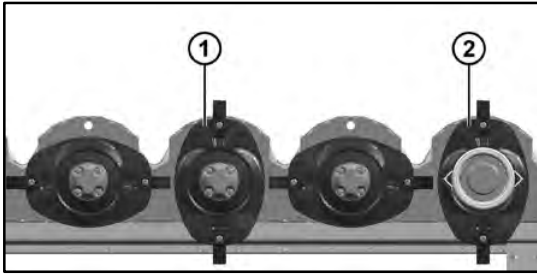

Fig. 61 Mower discs aligned

- ➔ Align mower disc (1) parallel to mower disc (2).



Fig. 62 Position of the new driveGUARD element

- ➔ Position the new driveGUARD element as shown.
- ➔ Make sure that all fastening holes of the driveGUARD element line up with the bolt holes of the mower disc.



Fig. 63 Tightening the inner bolts

- ➔ Insert the stop pin (1) back into the respective mower disc.
- ➔ Insert a bolt (2) into the outer bolt circle to prevent the element from turning.
- ➔ Tighten the 6 inner bolts (3) in a crosswise sequence. Observe the tightening torque of 110 Nm.



Important!

Risk of material damage from incorrect tightening sequence!

An incorrect tightening sequence of the inner bolts can bend the driveGUARD element out of shape or destroy it.

- ➔ Always tighten the inner bolts in a crosswise sequence.

- ➔ Remove the bolts from the outer bolt circle.

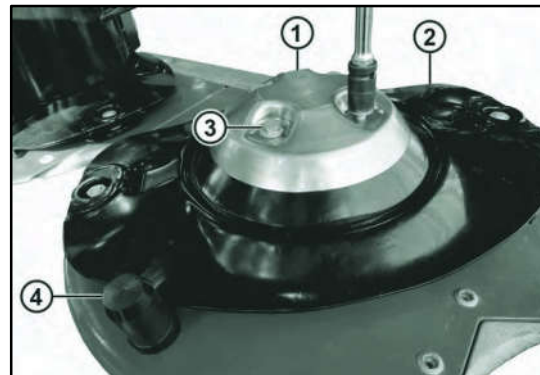

Fig. 64 Attach the cover

- ➔ Place the cover (1) on the mower disc (2).
- ➔ Tighten the 4 bolts (3). Observe the tightening torque of 110 Nm.
- ➔ Remove the stop pin (4).

Rectifying faults

12.3.3 Mower disc with feed drum

Removal

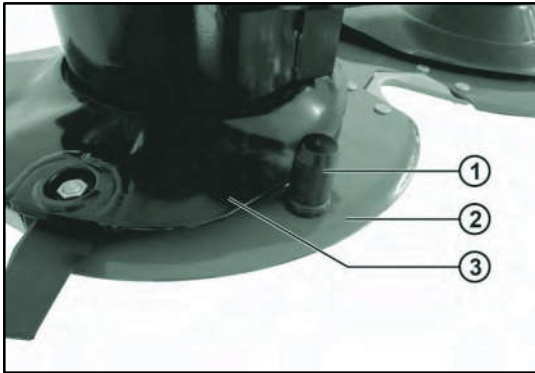

Fig. 65 Stop pin in stone guard disc

- ➔ Insert the stop pin (1) into the stone guard disc (2) of the respective mower disc (3).
- ➔ Rotate the mower disc to the stop pin to prevent the mower disc from rotating further.



Fig. 66 Remove cover

- ➔ Release the 4 screws (1) from the cover (2) of the feed drum.
- ➔ Remove the cover.

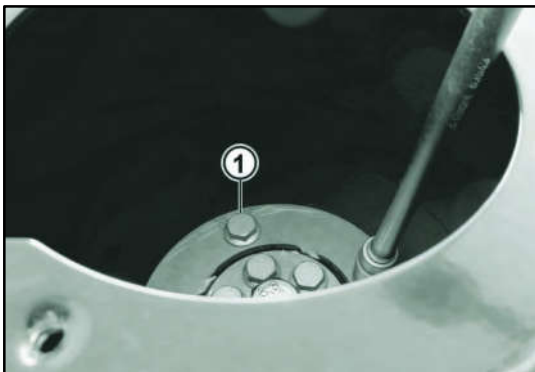

Fig. 67 driveGUARD - Outer bolts

- ➔ Release the 4 outer bolts (1) on the driveGUARD element using the socket spanner extension.

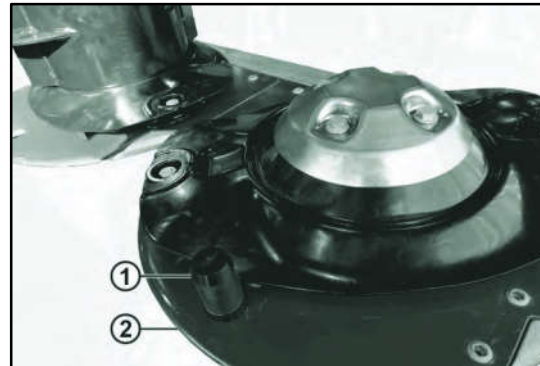

Fig. 68 Stop pin inserted in new position

- ➔ Insert the stop pin (1) into the adjacent mower disc (2).



Fig. 69 driveGUARD - Inner bolts

- ➔ Release the 6 inner bolts.
- ➔ Carefully remove all parts of the released driveGUARD element.

Installation

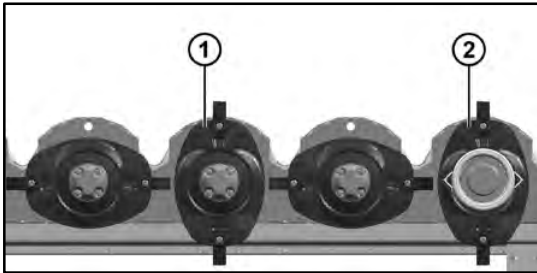

Fig. 70 Mower discs aligned

- ➔ Align mower disc (1) parallel to mower disc (2).



Fig. 71 Insert new driveGUARD element

- ➔ Insert a new driveGUARD element (1).

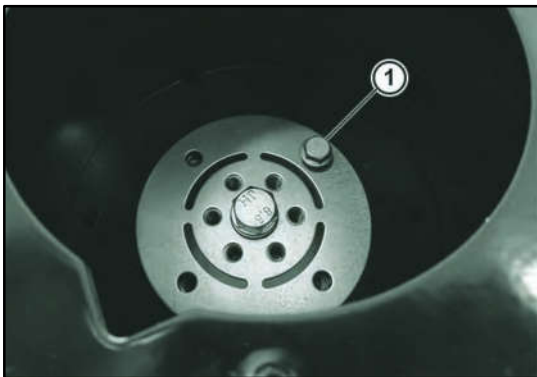

Fig. 72 Position of the new driveGUARD element

- ➔ Position the new driveGUARD element as shown.
- ➔ Make sure that all fastening holes of the driveGUARD element line up with the bolt holes of the mower disc.

- ➔ Insert the stop pin back into the respective mower disc.
- ➔ Insert a bolt (1) into the outer bolt circle to prevent the element from turning.

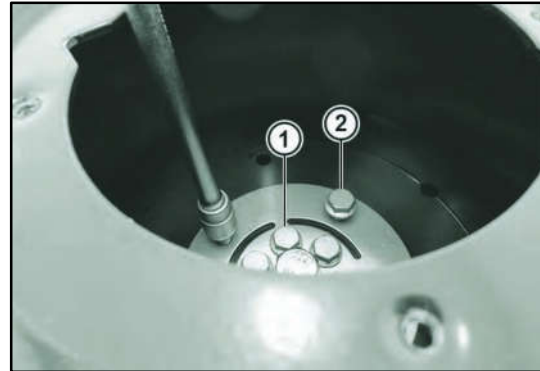

Fig. 73 Tighten bolts

- ➔ Tighten the 6 inner bolts (1) in a crosswise sequence. Observe the tightening torque of 110 Nm.



Important!

Risk of material damage from incorrect tightening sequence!

An incorrect tightening sequence of the inner bolts can bend the driveGUARD element out of shape or destroy it.

- ➔ Always tighten the inner bolts in a crosswise sequence.

- ➔ Tighten the 4 outer bolts (2). Observe the tightening torque of 110 Nm.



Fig. 74 Bolt down cover

- ➔ Place the cover (1) on the feed drum.
- ➔ Tighten the 4 bolts (2).
- ➔ Remove the stop pin.

Rectifying faults

12.3.4 Checks after replacing a driveGUARD element

- Check that the adjacent mower discs are at 90° to the mower disc with the replaced driveGUARD element.
- In event of a deviation from this angle, replace the driveGUARD element of the respective mower disc.
- Check the cutter blades for damage.
- Replace any damaged cutter blades.
- Check that the cutter blade holders are securely in place and are not damaged.
- Replace any loose or damaged cutter blade holders.
- Check the other parts (mower and stone guard discs, runners and connection parts) of the cutter bar for damage, and replace if necessary.
- Carefully start operating the machine again and listen out for unusual noises.
- If unusual noises occur, park the machine immediately and identify the cause.
- Consult a specialist workshop immediately if you cannot identify the cause of the unusual noises.

12.4 Overload protection system for the conditioner

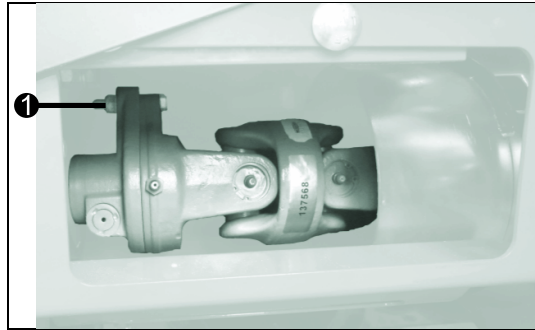

Fig. 75 Conditioner drive

- Turn both parts of the shear torque limiter until the broken shear bolt (1) can be removed.
- Remove the broken shear bolt (1) and insert a new one (M8x50-8.8 DIN 931 bolt).
- Tighten the new shear bolt to 25 Nm.

12.5 Blockages at the conditioner

- Reverse the tractor.
- Lift the machine.
- Clear any blockages still remaining by hand.



Warning!

Risk of injury from machine parts with sharp edges

Clearing blockages at the conditioner by hand may result in injury.

- Wear protective gloves.
- Only clear blockages when the machine is not running.

13 Servicing

 **Warning!**

Risk of injury from moving machine parts.

All maintenance work on the machine must be carried out when the machine is at a standstill.

- ➔ Apply the tractor parking brake.
- ➔ Switch off the tractor engine.
- ➔ Remove the ignition key.
- ➔ Secure the machine against rolling away.
- ➔ If maintenance work is being carried out on the raised machine, use suitable support elements to secure the machine against lowering and tipping over.

 **Important!**

Risk of material damage due to use of non-original spare parts.

Spare parts that do not fulfil the requirements reduce the machine's safety, reliability and performance.

➔ Use only original spare parts. Information on these can be found in the spare parts catalogue or obtained from your specialist workshop.

13.1 Maintenance intervals

Interval Maintenance task	Before each season	Before each use	After the first two hours of operation	All 50 hours of operation	All 500 hours of operation	After each use	As required	After 6 years	Special regulations
	Cleaning the machine							X	
Check the nuts and bolts to make sure they are secure.	X								
Tightening nuts and bolts			X				X		
Check that the adhesive notice is complete						X			
Replace adhesive notice							X		
Check PTO shaft		X							
Service PTO shaft									X ¹
Check hydraulic lines		X							
Replace hydraulic lines							X	X	
Check gearbox and cutter bar oil levels				X					
Change angle drive oil					X				
Change the oil in the entry gearbox and the cutter bar									X ²

Servicing

Maintenance task	Interval								
	Before each season	Before each use	After the first two hours of operation	All 50 hours of operation	All 500 hours of operation	After each use	As required	After 6 years	Special regulations
Check cutter blades and holders		X							
Replace cutter blades and/or holders							X		
Check the screen element in the TurboLift system				X					
Replace the screen element of the TurboLift system							X		
Check the protective covers		X							
Replace the protective cover							X		
Lubricate				X ³					

- 1) Refer to the PTO shaft manufacturer's Operating Instructions.
- 2) Only with repair
- 3) Refer to chapter 13.12 for lubrication instructions.

13.2 Accessing the maintenance points

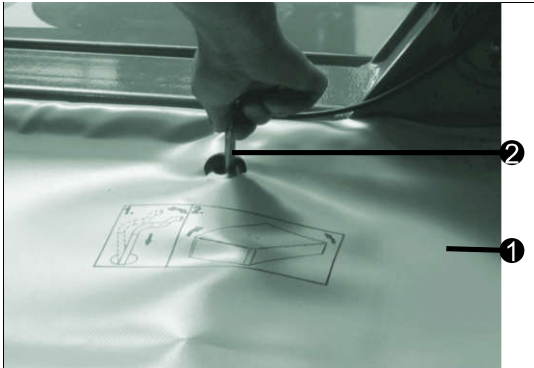

Fig. 76 Opening the protective cover of the cutter bar

- Using the special tool (2) provided, release the protective cover (1) and lift it up.

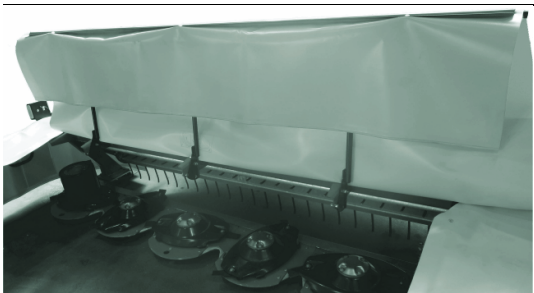

Fig. 77 Protective cover lifted up

- To close the guard, lower the protective cover. The locking mechanism locks automatically.

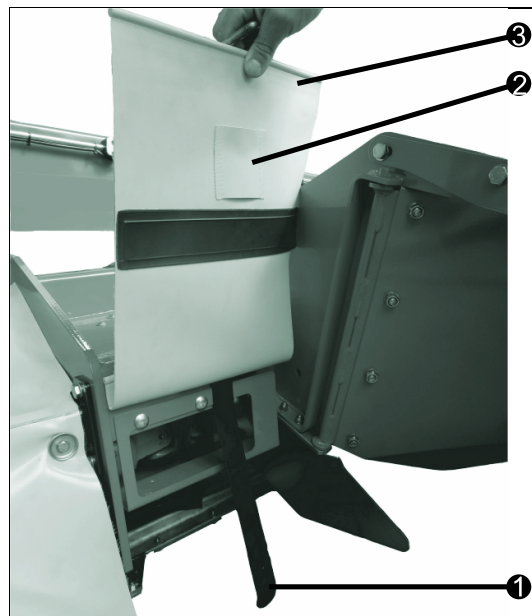

Fig. 78 Conditioner drive protective cover

- Remove the stabiliser (1) from the lug (2) and lift the protective cover (3) up.
- Lower the protective cover (3) and insert the stabiliser (1) back into the lug (2) to close the guard.

13.3 Cleaning



Important!

Risk of material damage as a result of using a high-pressure cleaner

Cleaning with a high-pressure cleaner may result in damage to the paintwork, which can lead to the formation of rust, or damage to the bearings.

- ➔ Do not use a high-pressure cleaner at all for cleaning bearings and hydraulic systems.
 - ➔ Do not use too much pressure when using the high-pressure cleaner to clean the machine.
-
- ➔ Remove any forage residue.
 - ➔ Lubricate the machine after cleaning according to the lubrication instructions (see section 13.12 Lubrication instruction).
 - ➔ Perform a quick trial run.
 - ➔ If the machine has had a prolonged period of downtime outdoors, clean the piston rods of the hydraulic cylinders and lubricate them with grease. Before initial operation, remove the grease from the piston rods.

13.4 Tightening torques for nuts and bolts

- ➔ Check the nuts and bolts to make sure they are secure.
- ➔ Tighten nuts and bolts in accordance with the tightening torques.

			Nm	ft lb
M 6 -	8.8		10	7
M 8 -	8.8		25	18
M 10 -	8.8		49	36
M 10 -	10.9		69	51
M 10 -	100	*VERBUS-RIPP®	105	78
M 12 -	8.8		86	63
M 12 -	10.9		120	89
M 12 -	100	*VERBUS-RIPP®	165	122
M 14 -	8.8		135	100
M 14 -	10.9		190	140
M 16 -	8.8		210	155
M 16 -	10.9		295	218
M 16 -	100	*VERBUS-RIPP®	410	302
M 20 -	8.8		410	302

* VERBUS-RIPP® is a self-locking fastener system.

13.5 Adhesive notices on the machine

- ➔ After each use, check all warnings and labels on the machine for completeness and legibility.
- ➔ Replace any illegible, damaged or missing labels.



Note

Section 2.6 Warning notices on the machine provides a general overview of all warnings and where they must be attached.

An overview of all the other adhesive notices can be found in section 3.2 Notices on the machine.

Servicing

13.6 PTO shaft



Important!

Risk of material damage as a result of incorrect maintenance of the PTO shaft

Incorrect maintenance can cause damage to the PTO shaft.

- Perform all necessary maintenance work in accordance with the operating instructions from the PTO shaft manufacturer.

- Check that all protection devices are fitted to the PTO shaft.



Important!

Risk of environmental damage from resources

Operating equipment and media that are not properly disposed of may be harmful to the environment.

- Make sure that all operating equipment and media are disposed of properly.

13.7 Hydraulic system



Warning!

Risk of injury as a result of the hydraulic system being highly pressurised

When working on the hydraulic system, highly pressurised fluids may leak out and cause injury. Before working on the hydraulic system:

- Lower the machine.
- Switch off the hydraulics.
- Depressurise the hydraulics.
- Switch off the tractor engine.
- Remove the ignition key.



Note

Hoses should not be used for more than **six years**, including any time spent in storage. The time in storage must **not exceed two years**. The date of manufacture is printed on the hose lines.

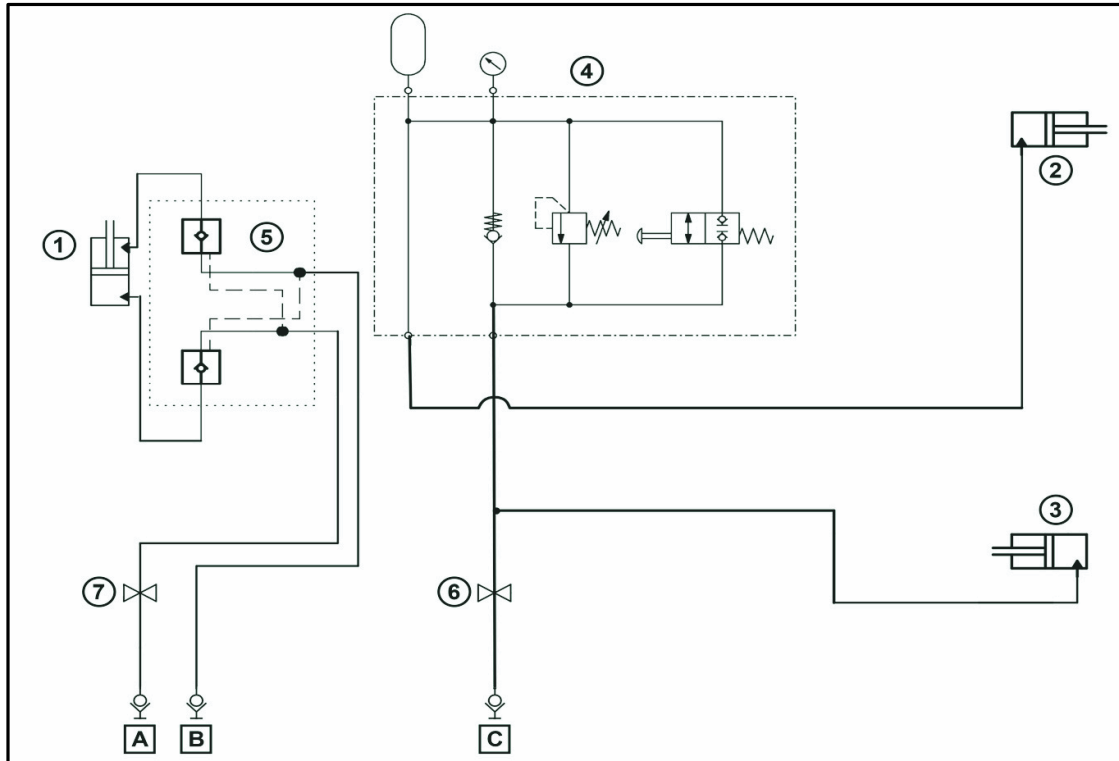

Fig. 79 Hydraulic plan

Item	Description	Function
A	Kennfixx adapter red, Plus	
B	Kennfixx adapter red, Minus	
C	Kennfixx adapter black, Plus	
1	Double-acting cylinder	For swinging from working position to transport position
2	Single-acting pressure cylinder	For lifting the mower unit
3	Plunger cylinder	For providing stability when in the headland position
4	Control block	For adjusting the balancing pressure
5	Shut-off valve	For shutting off the cylinder 1 during transportation
6	Block ball cock	
7	Block ball cock	

Servicing

13.8 Gearbox



Important!

Risk of environmental damage from resources

Operating equipment and media that are not properly disposed of may be harmful to the environment.

- Make sure that all operating equipment and media are disposed of properly.

13.8.1 Angle drive



Note

Please use the following oil when topping up: SAE 85W-90 GL5.

The fill quantity needed is 0.9 litres.

Oil level check

- Park the machine in working position on a level surface.

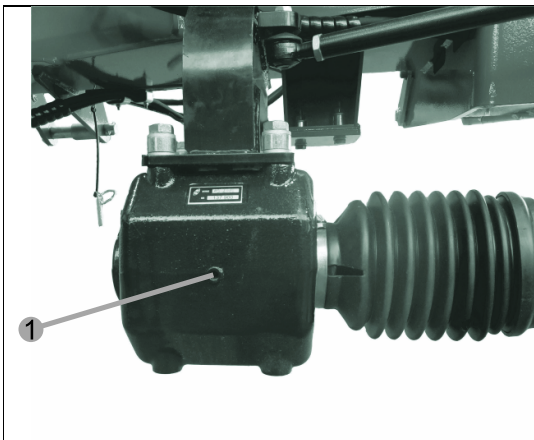

Fig. 80 Oil level check plug of the angle drive

- Unscrew the oil level check plug (1).

Correct oil level: Oil reaches the lower edge of the oil level check plug opening.

- Top up with oil if necessary.
- Screw the oil level check plug (1) back in and securely tighten it.

Oil change

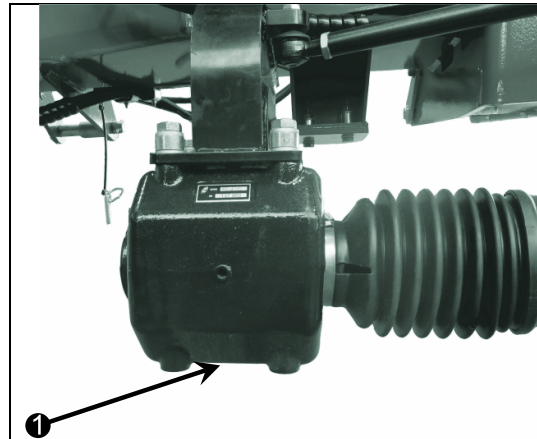

Fig. 81 Oil drain plug of the angle drive

- Place a sufficiently large container underneath the oil drain plug (1).
- Unscrew the oil drain plug (1).
- Allow the used oil to drain completely.
- Screw the oil drain plug (1) back in.
- Top up the oil.
- Check the oil level.

13.8.2 Entry gearbox and cutter bar



Note

Please use the following oil when topping up: SAE 85W-90 GL5.

The overall fill quantity needed is 13 litres.

Oil level check

The cutter bar and entry gearbox oil levels are measured at the entry gearbox.

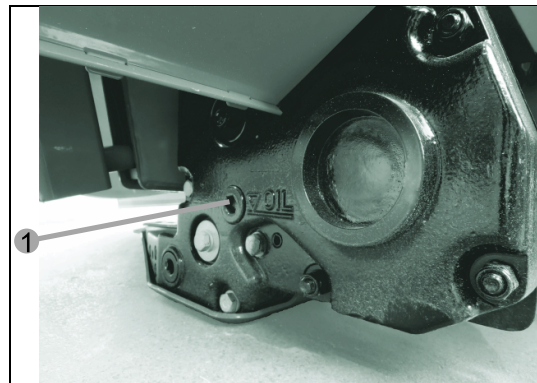

Fig. 82 Oil level check plug of the entry gearbox

- ➔ Place the machine in a horizontal position.
 - ➔ Unscrew the oil level check plug (1).
- Correct oil level: Oil reaches the lower edge of the oil level check plug opening.
- ➔ Top up with oil if necessary.
 - ➔ Screw the oil level check plug (1) back in and securely tighten it.

13.9 Cutter blades

Note

A holding spring and blade retaining bolt are only fitted for quick-change blade systems.

The quick-change blade system can be retrofitted (see section 3.3 Special equipment).

Warning!

Hazard caused by machine parts flying out of the machine

Worn cutter blades or their holders can become loose and be flung from the machine during use.

- ➔ Always check the cutter blades and ensure they are securely attached before use.

Caution!

Risk of injury from sharp edges and burrs

There is a risk of injury and cutting yourself when replacing parts with sharp edges.

- ➔ Wear protective gloves.

13.9.1 Checking the cutter blades

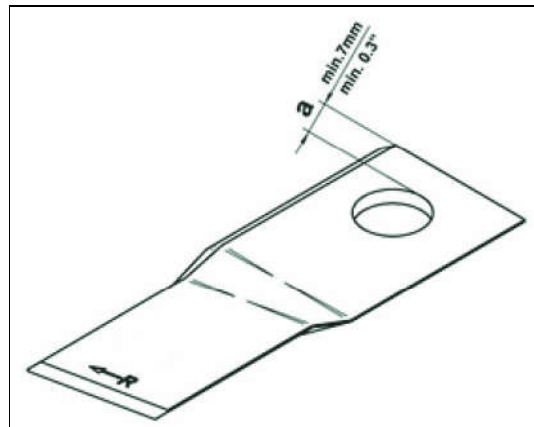

Fig. 83 Cutter blade edge distance

- ➔ Measure the cutter blade edge distance a from the mounting hole to the outer edge.
- ➔ If $a < 7$ mm, replace the cutter blade.

Important!

Risk of material damage from imbalance

Irregular running may result in damage to the machine.

- ➔ Always replace cutter blades in pairs.
- ➔ Always ensure the cutter blades are fitted according to the direction of rotation.

13.9.2 Checking the cutter-blade bolt

Only applicable for models without the quick-change blade system:

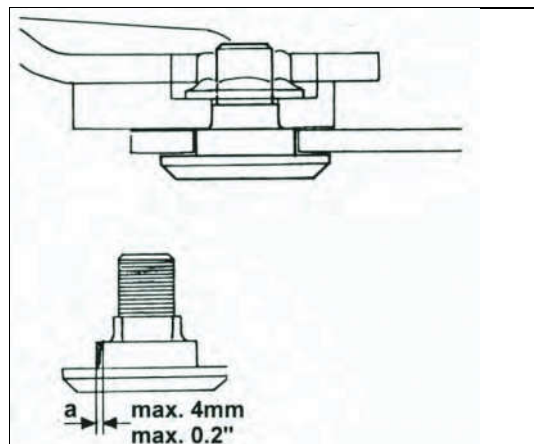

Fig. 84 Cutter-blade bolt wear

Servicing

- ➔ Measure the cutter-blade bolt wear a.
- ➔ If $a > 4$ mm, replace the cutter-blade bolt and the Verbus-Ripp nut.
- ➔ Check the square section and head for wear or damage, replacing the bolt and/or nut if necessary.



Important!

Risk of material damage from imbalance

Irregular running may result in damage to the machine.

- ➔ Always replace cutter-blade bolts in pairs.

13.9.3 Checking the blade retaining bolt

Only applicable for models with the quick-change blade system:

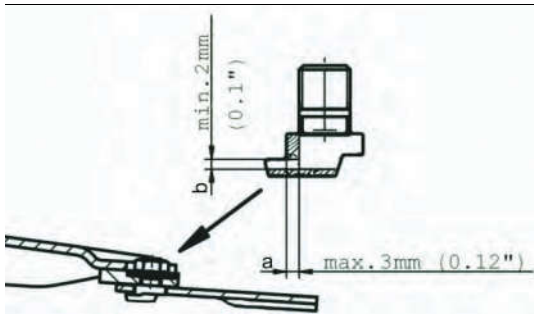

Fig. 85 Blade retaining bolt wear

- ➔ Measure the blade retaining bolt wear a.
- ➔ If $a > 3$ mm, replace the blade retaining bolt and the Verbus-Ripp nut.
- ➔ Check the square section and head (minimum height b 2 mm) for wear or damage, replacing the blade retaining bolt and/or nut if necessary.



Important!

Risk of material damage from imbalance

Irregular running may result in damage to the machine.

- ➔ Always replace the blade retaining bolt and holder in pairs.

13.9.4 Checking the holding spring

Only applicable for models with the quick-change blade system:

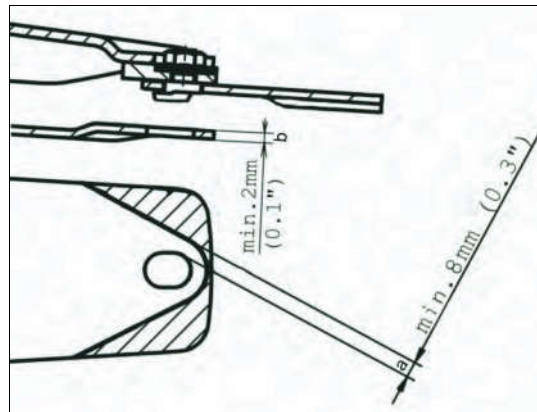

Fig. 86 Holding spring wear

- ➔ Measure the edge distance a and the height b of the holding spring.
- ➔ If $a < 8$ mm or $b < 2$ mm, replace the holding spring.

13.9.5 Replacing the cutter blades and/or cutter-blade bolt

Only applicable for models without quick-change blade system:

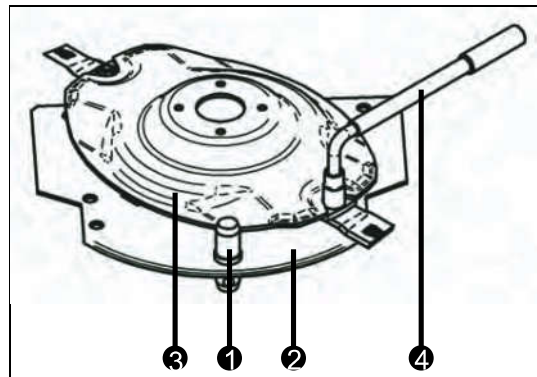

Fig. 87 Loosen the cutter blade

- ➔ Insert the stop pin (1) into the stone guard disc (2) of the affected mower disc (3).
- ➔ Turn the mower disc (3) until contact is made.
- ➔ Check that the mower discs are aligned.

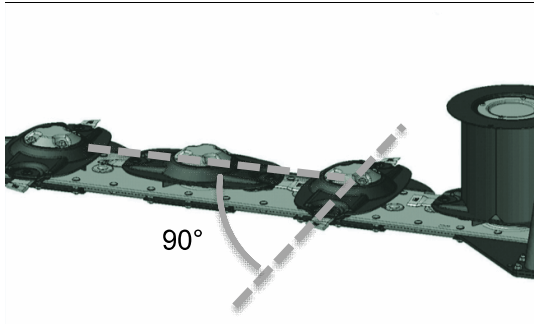

Fig. 88 Correct alignment of the mower discs

- ➔ The driveGUARD element has turned out of position if one of the mower discs is not positioned at a right angle. Replace the driveGUARD element (see section 12.3 Replacing the driveGUARD).



Note

This is a precautionary measure. driveGUARD elements with shearing areas that have been significantly twisted may be triggered for no apparent reason.

- ➔ Remove any dirt from around the cutter-blade attachment.
- ➔ Using the socket spanner (4), loosen the cutter-blade bolt.



Important!

Risk of material damage from imbalance

Irregular running may result in damage to the machine.

- ➔ Always replace cutter blades and cutter-blade bolts in pairs.
- ➔ Always ensure the cutter blades are fitted according to the direction of rotation.



Fig. 89 Replacing the cutter blade

- ➔ Replace the cutter blade (1) and/or the cutter-blade bolt (2) and the Verbus-Ripp nut (3).

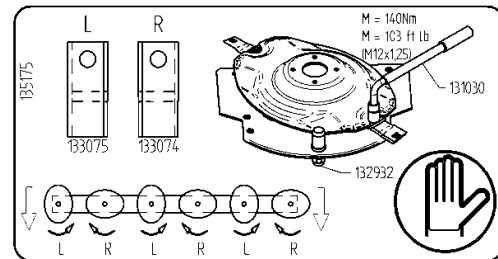

Fig. 90 Direction of rotation of the cutter discs

- ➔ Fasten the cutter blade using the cutter-blade bolt and the Verbus-Ripp nut.
- ➔ Observe the direction of rotation of the mower disc.
- ➔ Tighten the bolt with the socket spanner.
- ➔ Observe the tightening torque of 140 Nm (130 ft lb).
- ➔ Remove the stop pin from the stone guard disc.

13.9.6 Replacing the cutter blades

Only applicable for models with the quick-change blade system:



Important!

Risk of material damage from imbalance

Irregular running may result in damage to the machine.

- ➔ Always replace cutter blades in pairs.
- ➔ Always ensure the cutter blades are fitted according to the direction of rotation.

Servicing



Note

A key is provided for the quick-change blade system.

- ➔ Use the key provided for replacing the cutter blades.
- ➔ Remove any dirt from around the cutter-blade attachment.

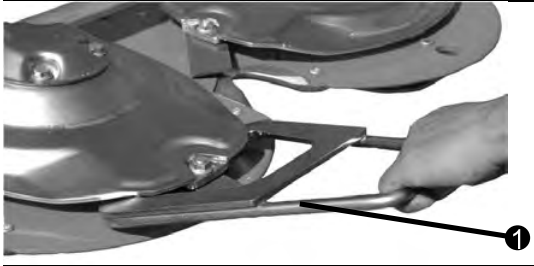

Fig. 91 Inserting the key

- ➔ Insert the key (1).



Fig. 92 Removing the cutter blades

- ➔ Turn the key (1) upwards.
- ➔ Remove the used cutter blade (2).

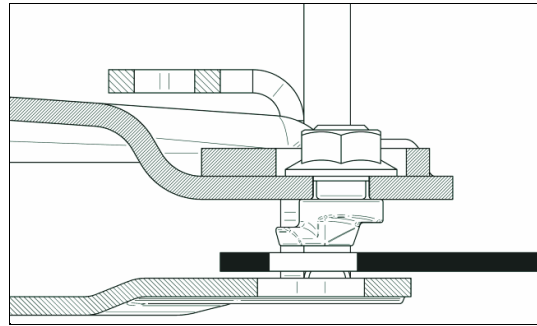

Fig. 93 Cutter blade on the blade retaining bolt

- ➔ Slide the new cutter blade over the blade retaining bolt.

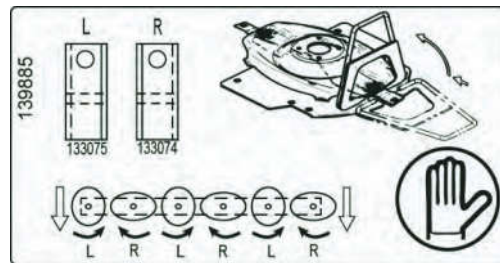

Fig. 94 Direction of rotation of the cutter discs

- ➔ Observe the direction of rotation of the mower disc.
- ➔ Turn the key downwards and remove it.

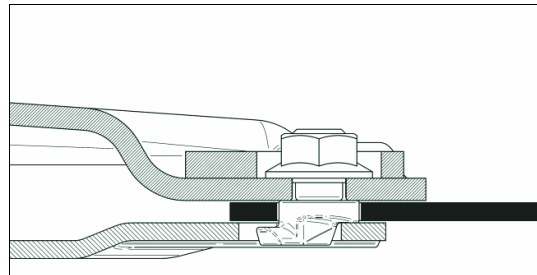

Fig. 95 Checking the cutter blade seating

- ➔ Check whether the cutter blade is correctly positioned on the blade retaining bolt.

13.9.7 Replacing the blade retaining bolt and/or the holding spring

- ➔ Clean the relevant mower disc.
- ➔ Insert the stop pin into the stone guard of the relevant mower disc.
- ➔ Rotate the mower disc as far as it will go to prevent it from rotating further.
- ➔ Remove the cutter blades from the relevant mower disc.

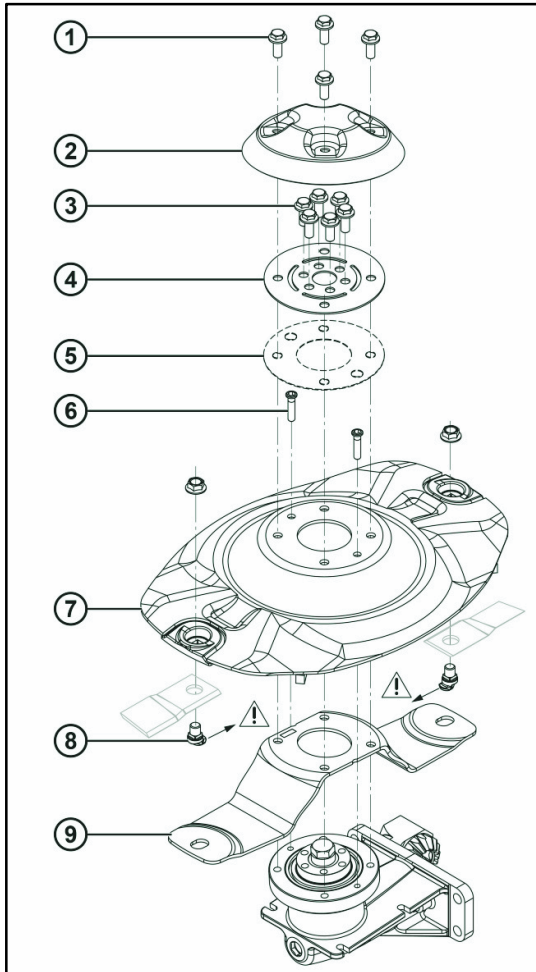

Fig. 96 Fitting the retaining bolt and retaining spring

- ➔ Disassemble the mower disc. Start with the bolts (1).
- ➔ If necessary, replace the VERBUS-RIPP® nut and retaining bolt (8) in pairs.

Retaining bolt tightening torque: 140 Nm

- ➔ Make sure that the retaining bolt lugs face towards the centre of the mower disc.

- ➔ Replace the retaining spring (9) as required.
- ➔ Assemble the mower disc in the reverse order. Start with the retaining spring (9).

Bolt tightening torque (6): 30 Nm

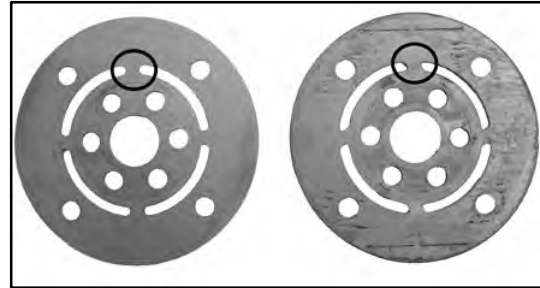

Fig. 97 Left: Normal element
Right: Twisted element

- ➔ Check the driveGUARD element (4) to see whether the shearing areas have been twisted.

This is a precautionary measure. driveGUARD elements with shearing areas that have been significantly twisted may be triggered for no apparent reason.

If the shearing areas have been significantly twisted (degree of twisting as in Fig. 97):

- ➔ Replace the driveGUARD elements (see section 12.3 Replacing the driveGUARD)

If the shearing areas have not been twisted:



Fig. 98 Position of the driveGUARD element

- ➔ Position the driveGUARD element as shown.
- ➔ Tighten the six inner bolts (Fig. 96, 3) in a crosswise sequence.

Servicing

Bolt tightening torque (Fig. 96, 3): 110 Nm

- ➔ Fit the cover (Fig. 96, 2) to the driveGUARD element.

Bolt tightening torque (Fig. 96, 1): 110 Nm

- ➔ Fit the cutter blades as described under "Replacing the cutter blades".

13.10 Screen element of the TurboLift system



Danger!

Risk of injury from the machine slipping, lowering or tipping over

If the machine slips, lowers or tips over, anyone standing near it may be put at risk.

- ➔ Park the machine on level and firm ground.
- ➔ Ensure the machine is sufficiently stable.

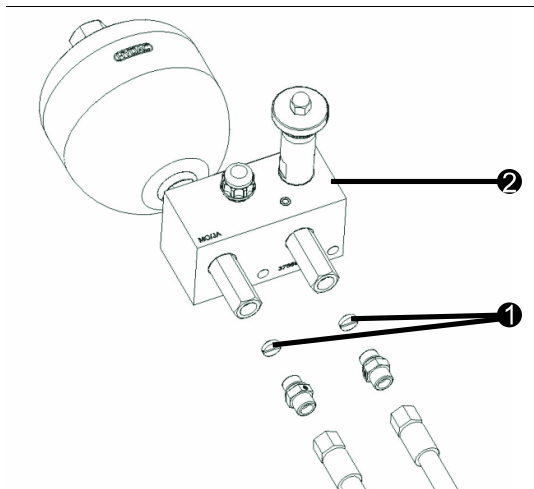

Fig. 99 Screen element of the control device

- ➔ Release the TurboLift system pressure. The pressure gauge needle must be at 0.
- ➔ Place a container under the control device to collect any escaping oil.
- ➔ Check that the screen element (1) of the control device (2) is not dirty.
- ➔ If necessary, clean the screen element (1) using compressed air.

- ➔ Replace the screen element (1) as required.

13.11 Check the protective covers



Danger!

Risk of injury from flying stones

If protective covers are damaged or have been attached and/or closed incorrectly, people may be injured as a result of flying stones or similar debris.

- ➔ Place all safety equipment in the safety position before using the machine.
- ➔ Do not modify the safety equipment.
- ➔ Check the protective covers for damage and/or wear before each use.
- ➔ Replace the protective covers as required.

13.12 Lubrication instruction



Important!

Risk of environmental damage from resources

Operating equipment and media that are not properly disposed of may be harmful to the environment.

- ➔ Make sure that all operating equipment and media are disposed of properly.

No.	Lubricating point	Quantity	Interval	Type of maintenance	Amount	Lubricant
1	Transmission console mounting	1	50h	Lubricate	according to requirement	Multipurpose grease
2	Hinge bracket mounting	1	50h	Lubricate	according to requirement	Multipurpose grease
3	Lifting arm bearing	1	50h	Lubricate	according to requirement	Multipurpose grease
4	Lifting cylinder mounting	1	50h	Lubricate	according to requirement	Multipurpose grease
5	Pivot pin	2	50h	Lubricate	according to requirement	Multipurpose grease

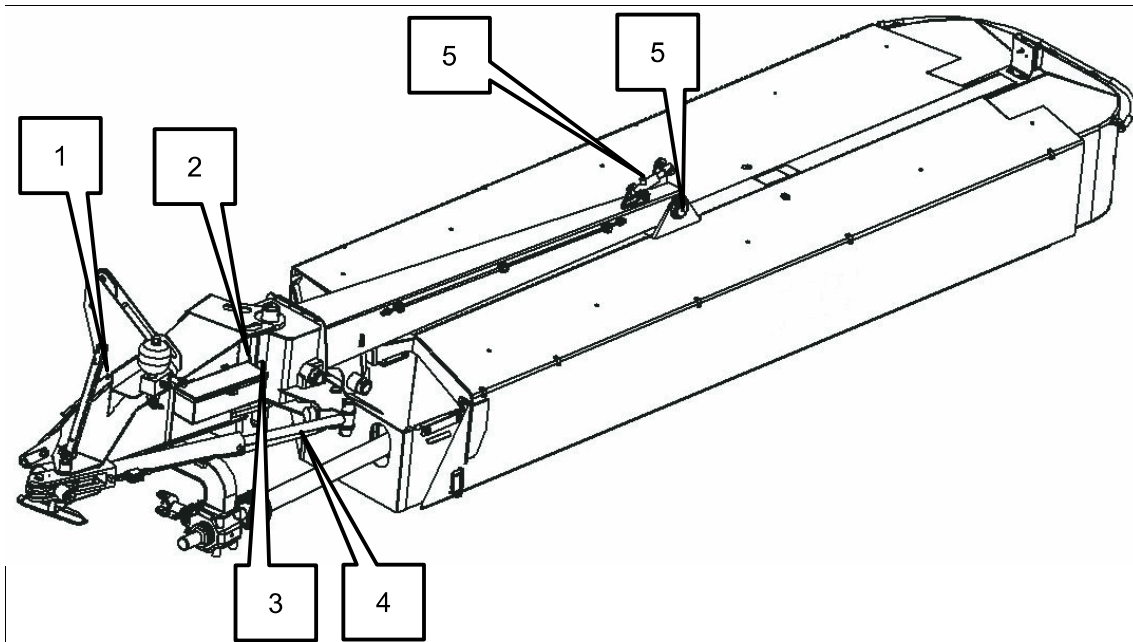

Fig. 100 Mower unit lubricating points

Servicing

KC

No.	Lubricating point	Quantity	Interval	Type of maintenance	Amount	Lubricant
6	Shear torque limiter	1	250h	Lubricate	according to requirement	Multipurpose grease
7	Universal joint	2	250h	Lubricate	according to requirement	Multipurpose grease
8	Rotor mounting	2	50h	Lubricate	according to requirement	Multipurpose grease

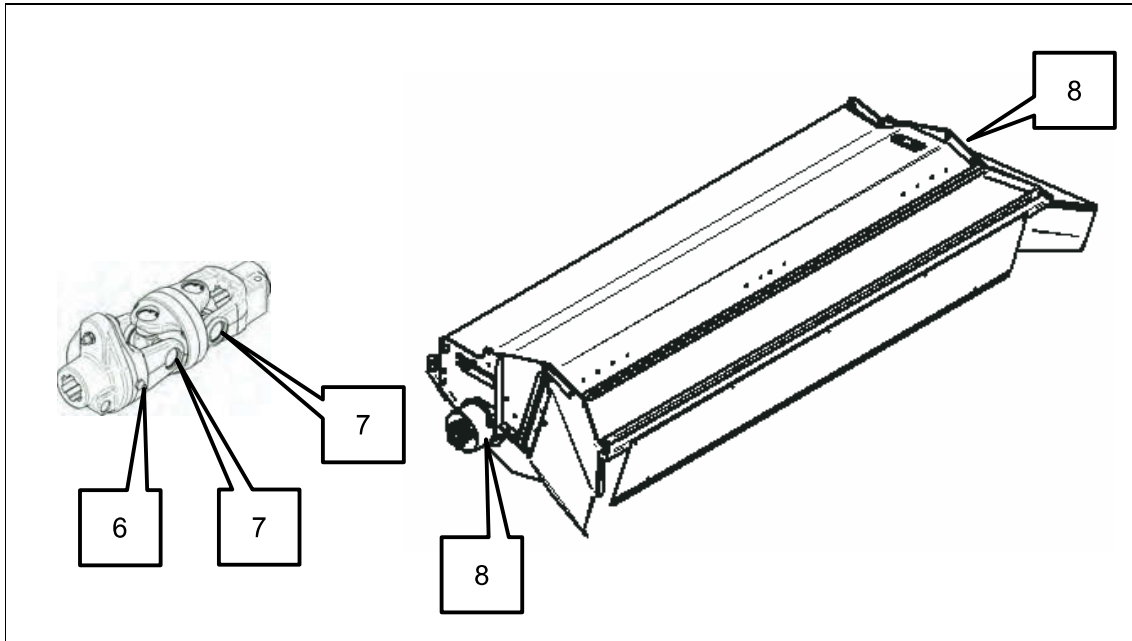

Fig. 101 Lubricating points of the KC

RC

No.	Lubricating point	Quantity	Interval	Type of maintenance	Amount	Lubricant
9	Shear torque limiter	1	250h	Lubricate	according to requirement	Multipurpose grease
10	Universal joint	2	250h	Lubricate	according to requirement	Multipurpose grease
11	Rotor mounting	4	50h	Lubricate	according to requirement	Multipurpose grease
12	Lever mounting	2	50h	Lubricate	according to requirement	Multipurpose grease

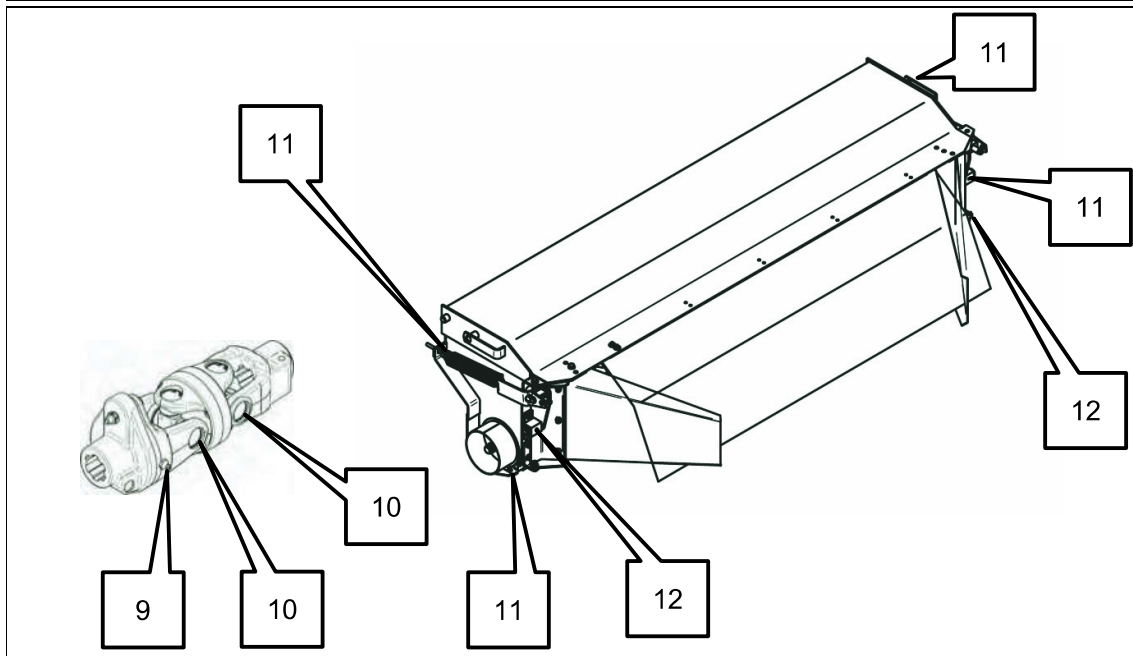

Fig. 102 Lubricating points of the RC

Servicing

Mower unit lubricating points

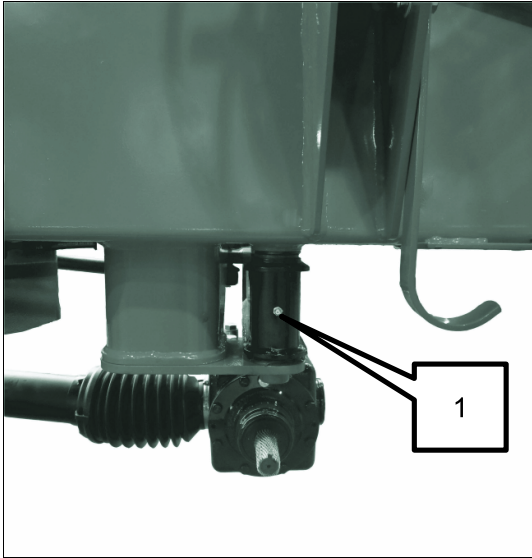

Fig. 103 1 Transmission console mounting

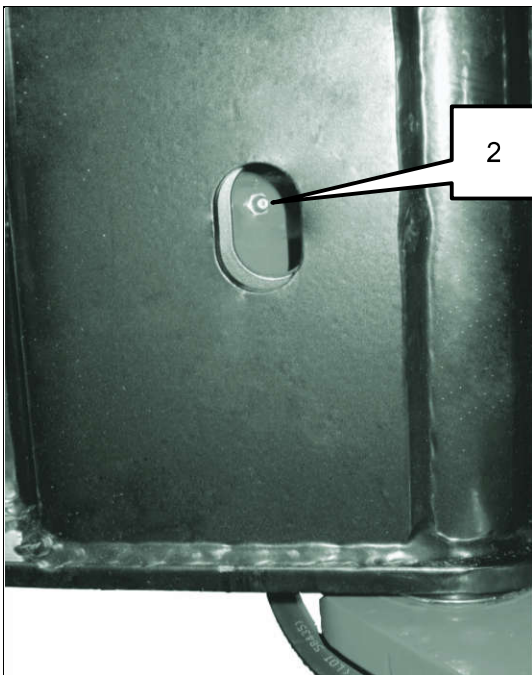

Fig. 104 2 Hinge bracket mounting



Fig. 105 3 Lifting arm bearing

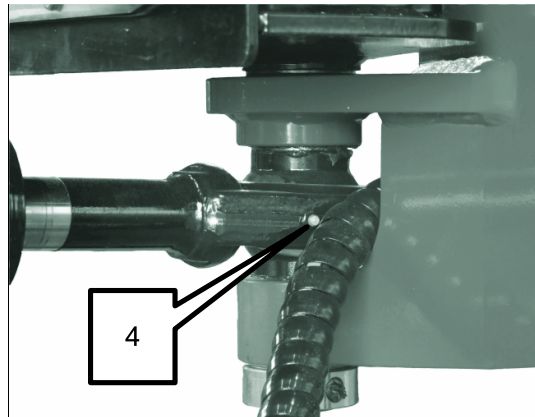

Fig. 106 4 Lifting cylinder mounting

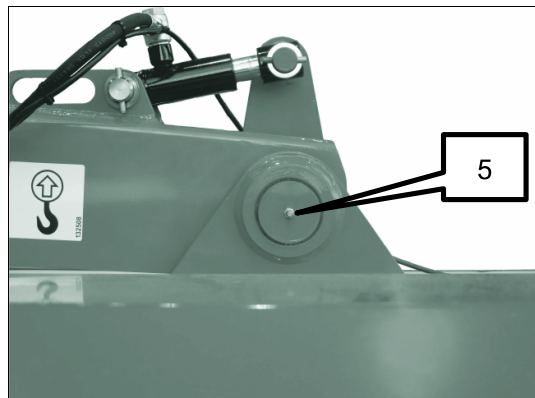

Fig. 107 5 Pivot pin (left and right)

KC lubricating points

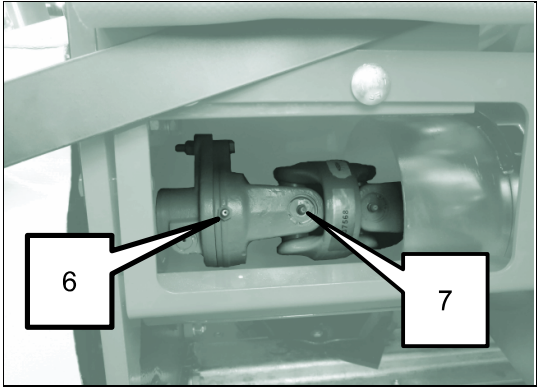

Fig. 108 6 Shear torque limiter
7 Universal joint 2x

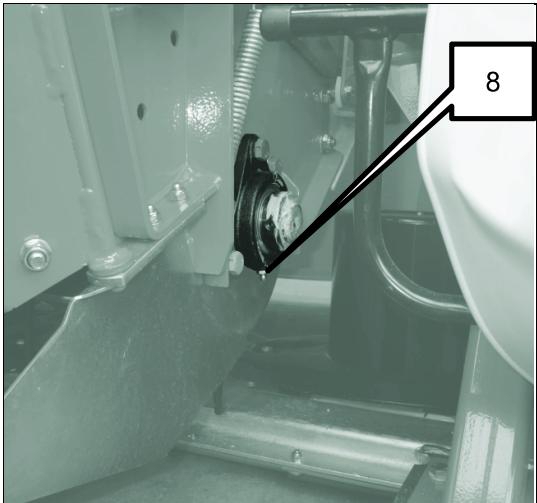

Fig. 109 8 Rotor mounting (left and right)

RC lubricating points

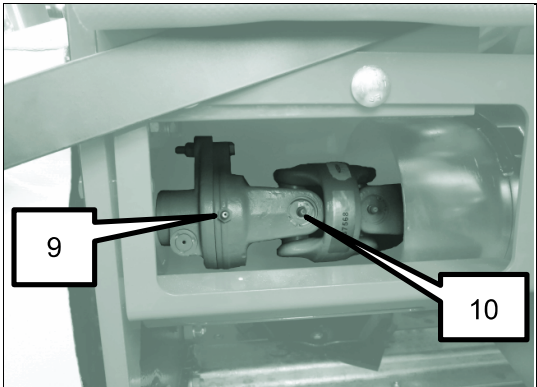

Fig. 110 9 Shear torque limiter
10 Universal joint 2x

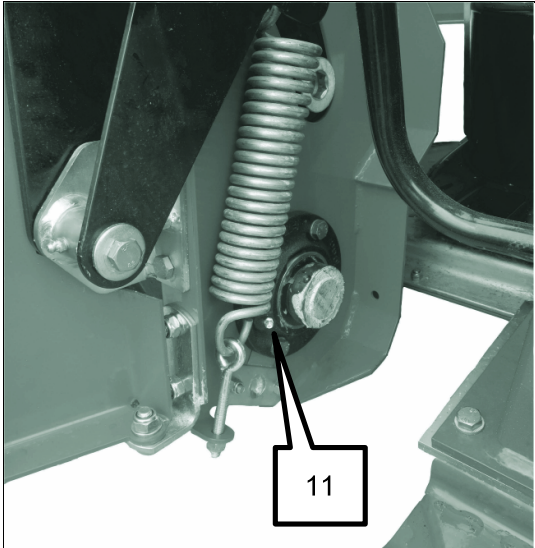

Fig. 111 11 Rotor mounting (left and right,
upper and lower)

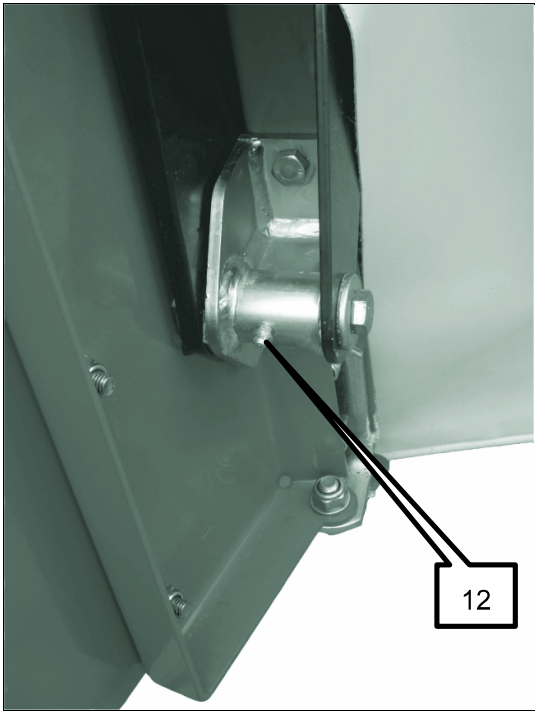

Fig. 112 12 Lever mounting

Index

14 Index

Adjusting cutting height	28	KC lubricating points	59
Angle drive		Lubrication instruction.....	54
Oil change	48	Mower unit lubricating points	58
Oil level check.....	48	RC lubricating points	59
Anti collision device		Machine	
adjustment	37	Adhesive notice.....	13
Assembling the machine	19	Components.....	15
Attachment to the tractor	21	coupling.....	21
Axle loads, gross weight, minimum ballast required	18	Description	12
Conditioner		Driving on the road	26
Adjusting the KC swath guiding assembly	30	Parking.....	33
overload protection system replacement	42	Product features.....	12
Conditioners		Switching to transport position.....	25
Adjusting the KC conditioner intensity	29	Using.....	27
Adjusting the RC conditioner intensity	30	Noise data.....	17
Adjusting the RC swath guiding assembly	31	Optional functions	
Connecting the lighting.....	24	Anti-wear skids	32
Cutter blades		KC spreader	32
carry out maintenance	49	Swath guiding disc	32
Checking the blade retaining bolt.....	50	Other applicable documentation.....	3
Checking the cutter-blade bolt	49	PTO shaft	
Checking the holding spring.....	50	Adjusting	19
checks	49	carry out maintenance	46
Replacing the blade retaining bolt/holding spring.....	53	Connecting to the tractor	23
Replacing the cutter blades using the quick-change blade system.....	51	Shortening.....	20
Replacing the cutter blades/cutter-blade bolt.....	50	Recommendations for longer service life	34
driveGUARD		Rectifying faults	35
replacement.....	37	Safety	5
Entry gearbox and cutter bar		Warnings and symbols	6
Oil level check.....	48	Safety instructions.....	9
Hydraulic system		General	10
carry out maintenance	46	Special	11
Connecting	24	Serial number	4
Initial operation.....	21	Servicing.....	43
Intended use	5	Accessing the maintenance points	44
Introduction	3	Adhesive notices on the machine	45
Lubricate		Check the protective covers	54
		Cleaning	45
		Gearbox	48
		Maintenance intervals.....	43
		Tightening nuts and bolts	45
		Settings.....	28

Index

Special equipment.....	14	Depressurising	33
Specifications	16	Maintaining the screen element.....	54
Switching to working position.....	26	User qualifications.....	5
TurboLift system		Warning notices on the machine	7
Adjusting the ground pressure	28		

AGCO® has Parts Distribution Centers strategically located to provide your MASSEY FERGUSON® Dealer with quality replacement parts in a timely manner.

In addition to quality repair parts, the company offers numerous accessories and a full line of quality filters and lubricants.

Protect your investment with parts and service from your MASSEY FERGUSON® Dealer.

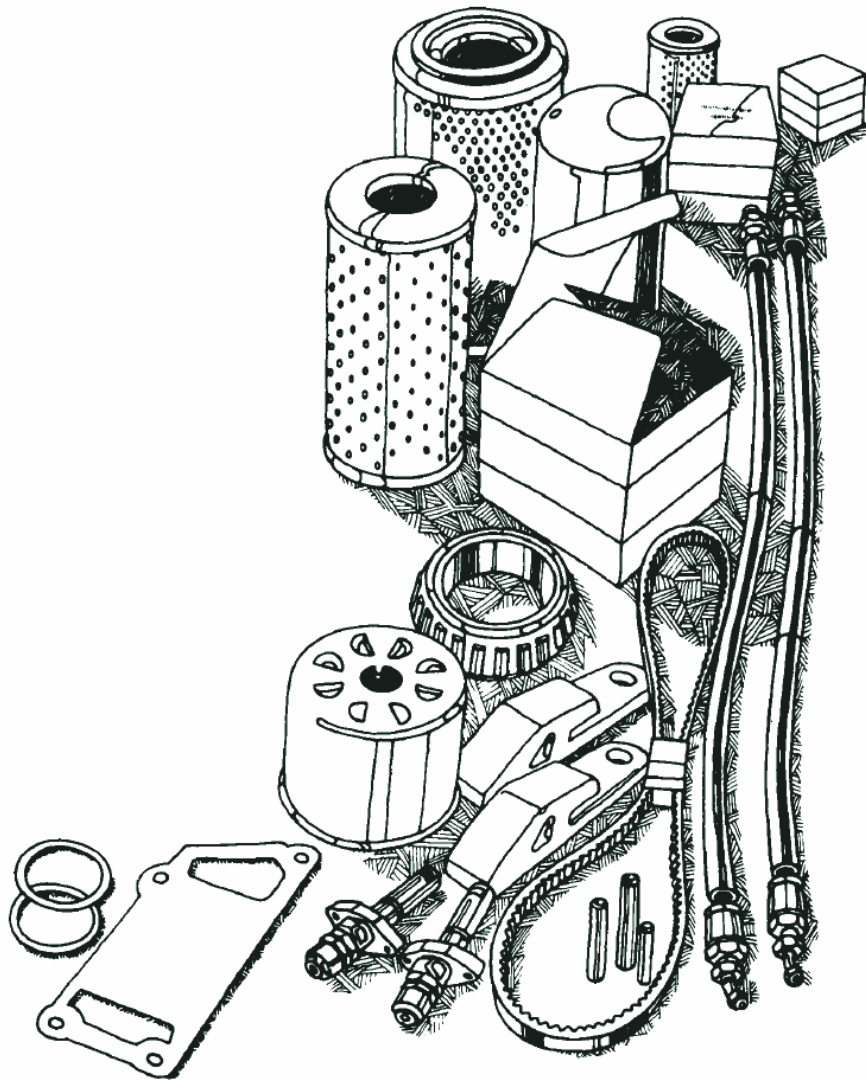

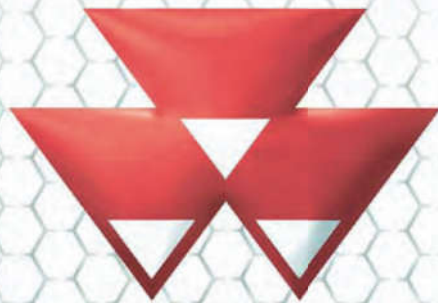

MASSEY FERGUSON

A world of experience. Working with you.

DM 306 TL	ABV	00141
DM 306 TL-KC	ALX	00108
DM 306 TL-RC	AKX	00101