

INTERACTIVE SCHEMATIC

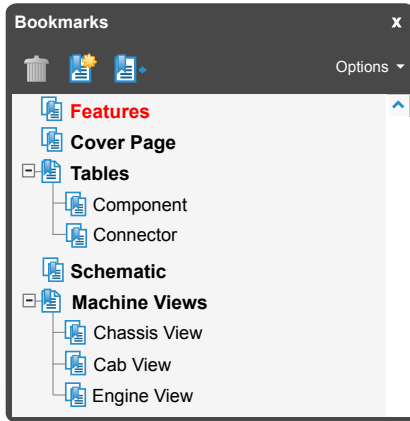

The Bookmarks panel will allow you to quickly navigate to points of interest.

****This document is best viewed at a screen resolution of 1024 X 768.***

To set your screen resolution do the following:

RIGHT CLICK on the **DESKTOP**.

Select **PROPERTIES**.

CLICK the **SETTINGS TAB**.

MOVE THE SLIDER under **SCREEN RESOLUTION** until it shows **1024 X 768**.

CLICK OK to apply the resolution.

**Due to different monitor sizes and PDF reader preferences there may be some variance in linked schematic locations*

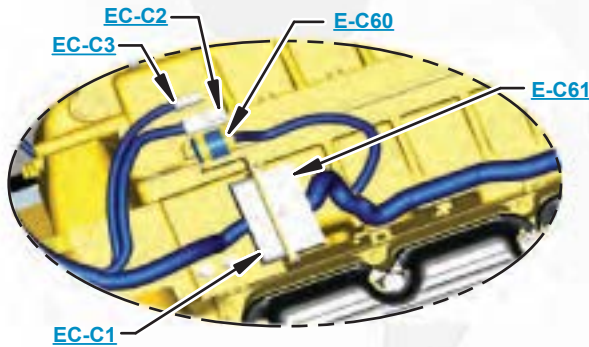

Click on any text that is **BLUE** and underlined. These are hyperlinks that can be used to navigate the schematic and machine views.



[Click here to save a copy of this interactive schematic to your desktop](#)

VIEW ALL CALLOUTS

When only one callout is showing on a machine view, clicking on this button will make all of the callouts visible. This button is located in the top right corner of every machine view page.

HOTKEYS (Keyboard Shortcuts)

	FUNCTION	KEYS
	Zoom In	“CTRL” / “+”
	Zoom Out	“CTRL” / “-”
	Fit to Page	“CTRL” / “0” (zero)
	Hand Tool	“SPACEBAR” (hold down)
	Find	“CTRL” / “F”
	Search	“CTRL” / “SHIFT” / “F”

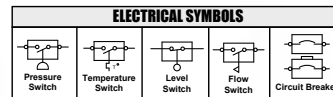

[Click here to view the Schematic Symbols and Definitions page](#)

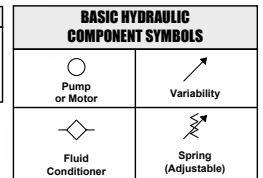

SCHEMATIC SYMBOLS AND DEFINITIONS

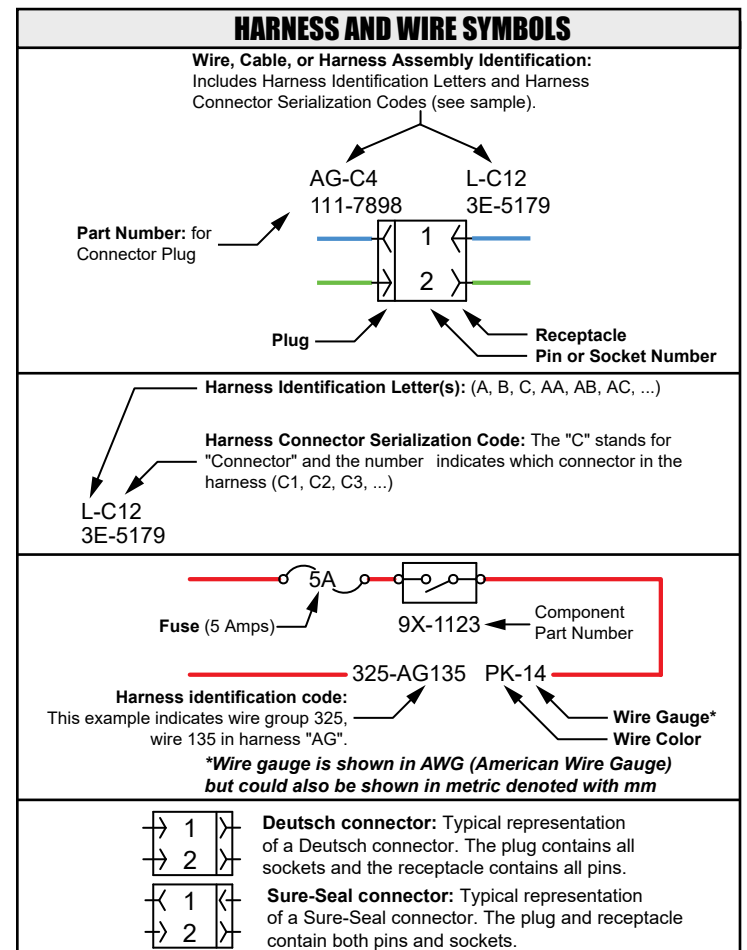
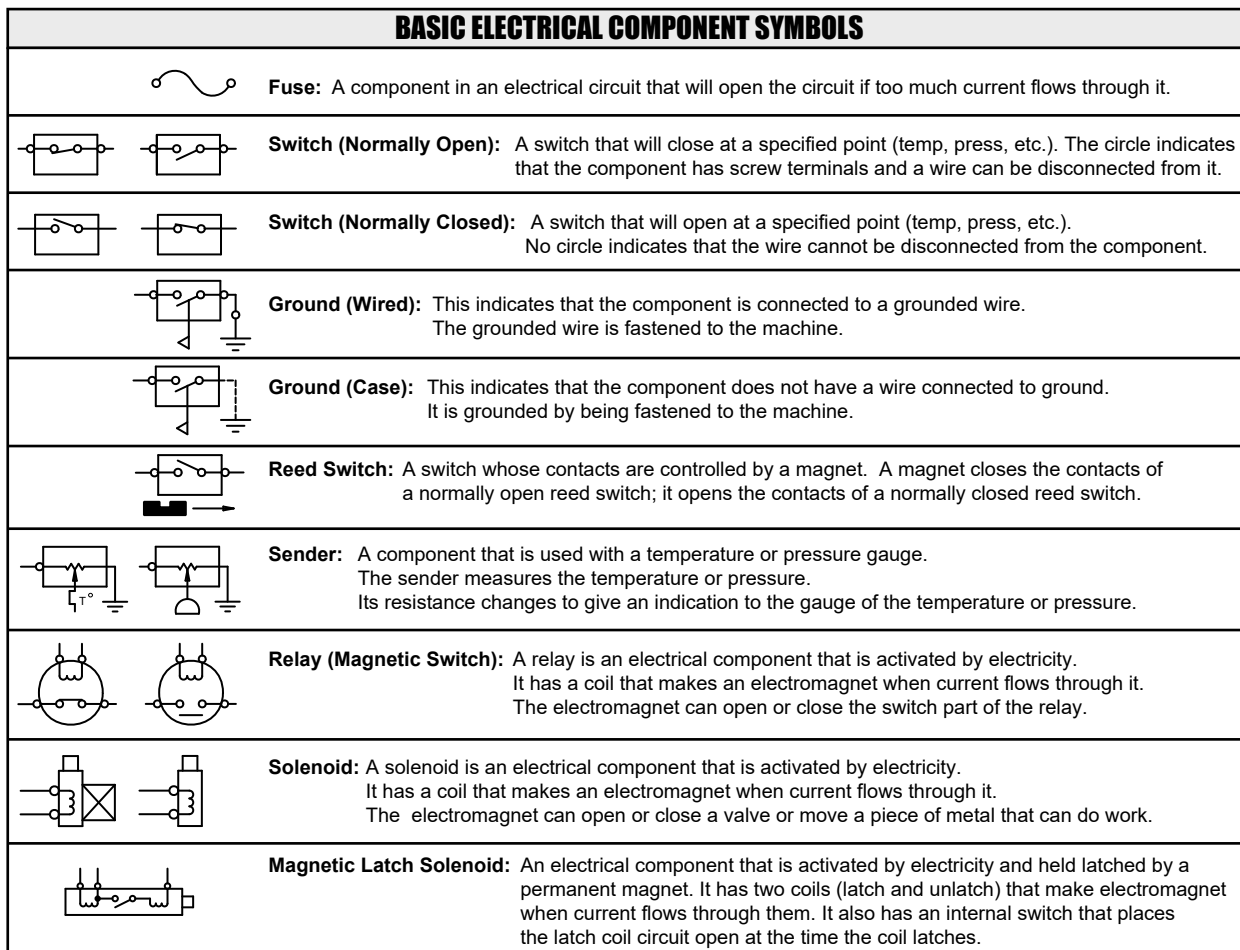
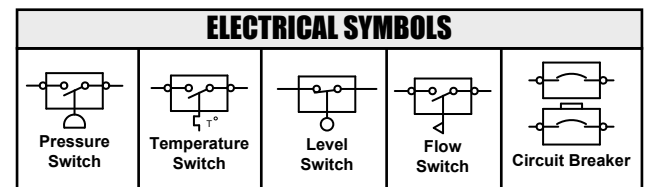
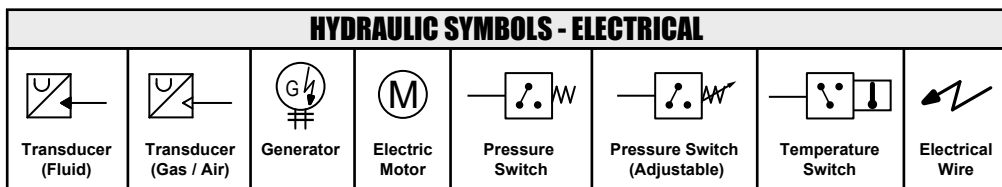
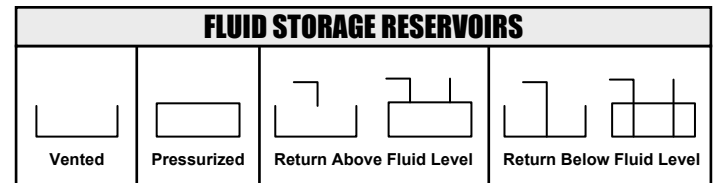
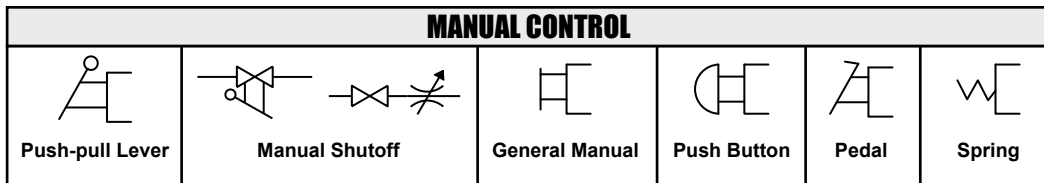
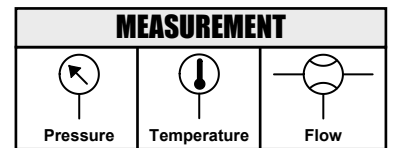
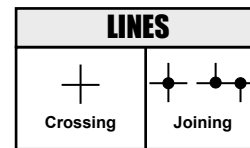
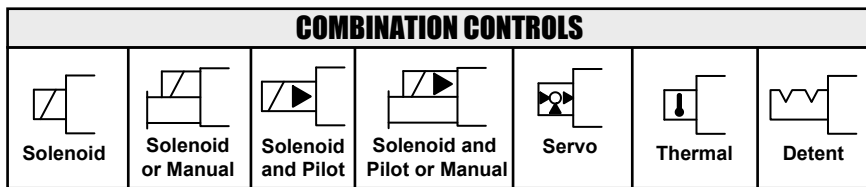
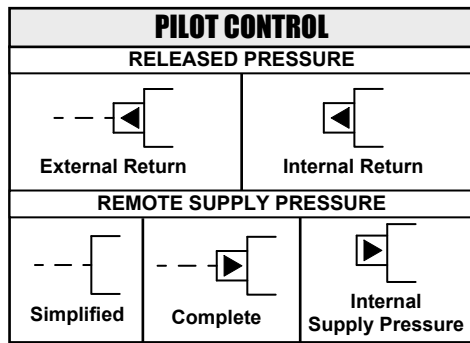
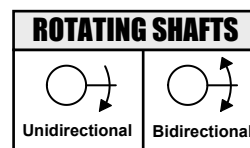
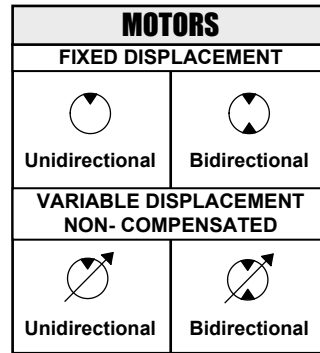
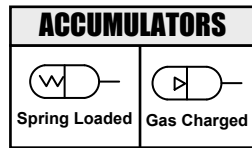
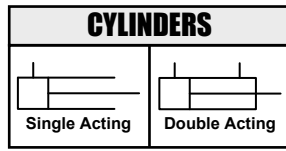
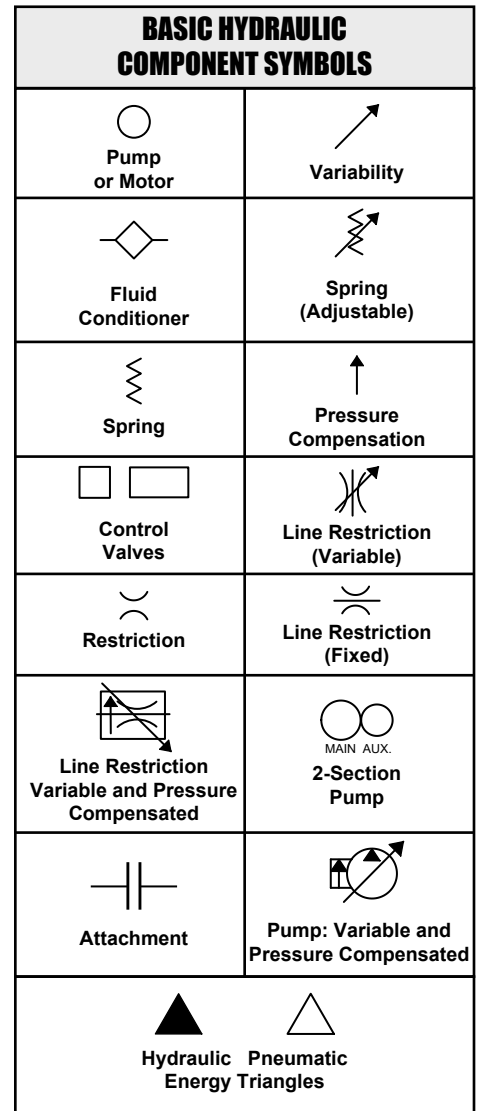
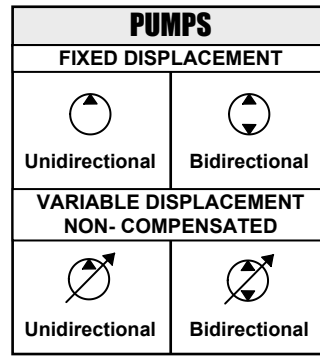
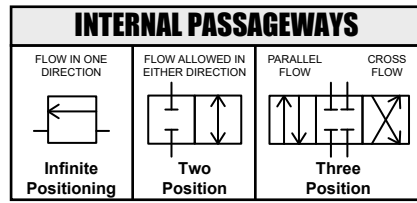
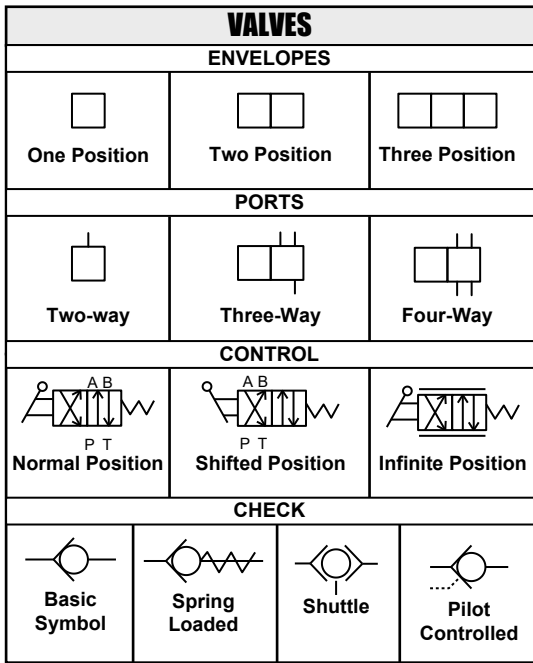



Schematic

C32 SCAC Commercial Engine Electrical System

C32286-UP
RSD569-UP
RTK283-UP
SDN1259-UP

ENGINE LEFT SIDE VIEW

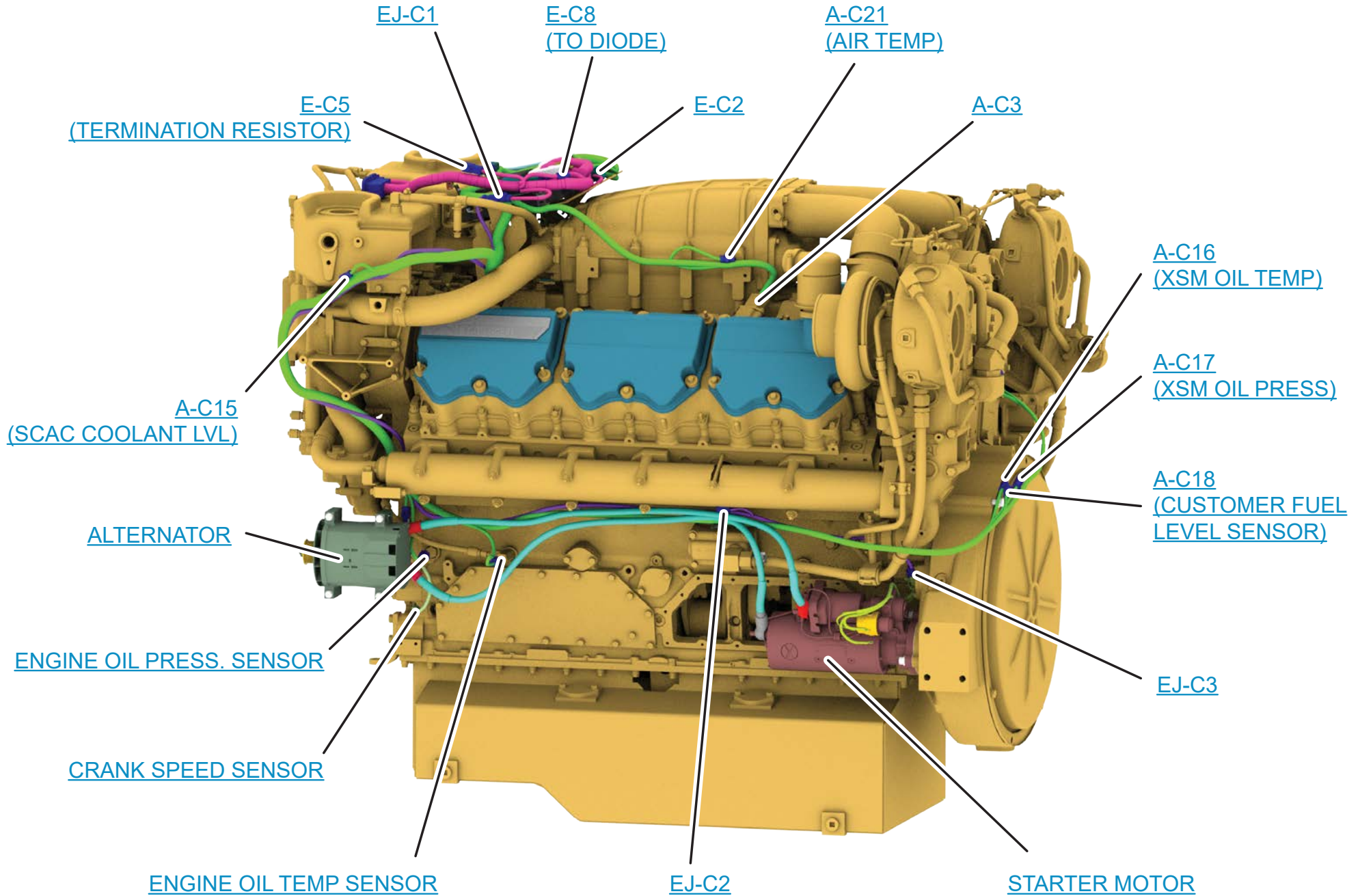

ENGINE REAR VIEW

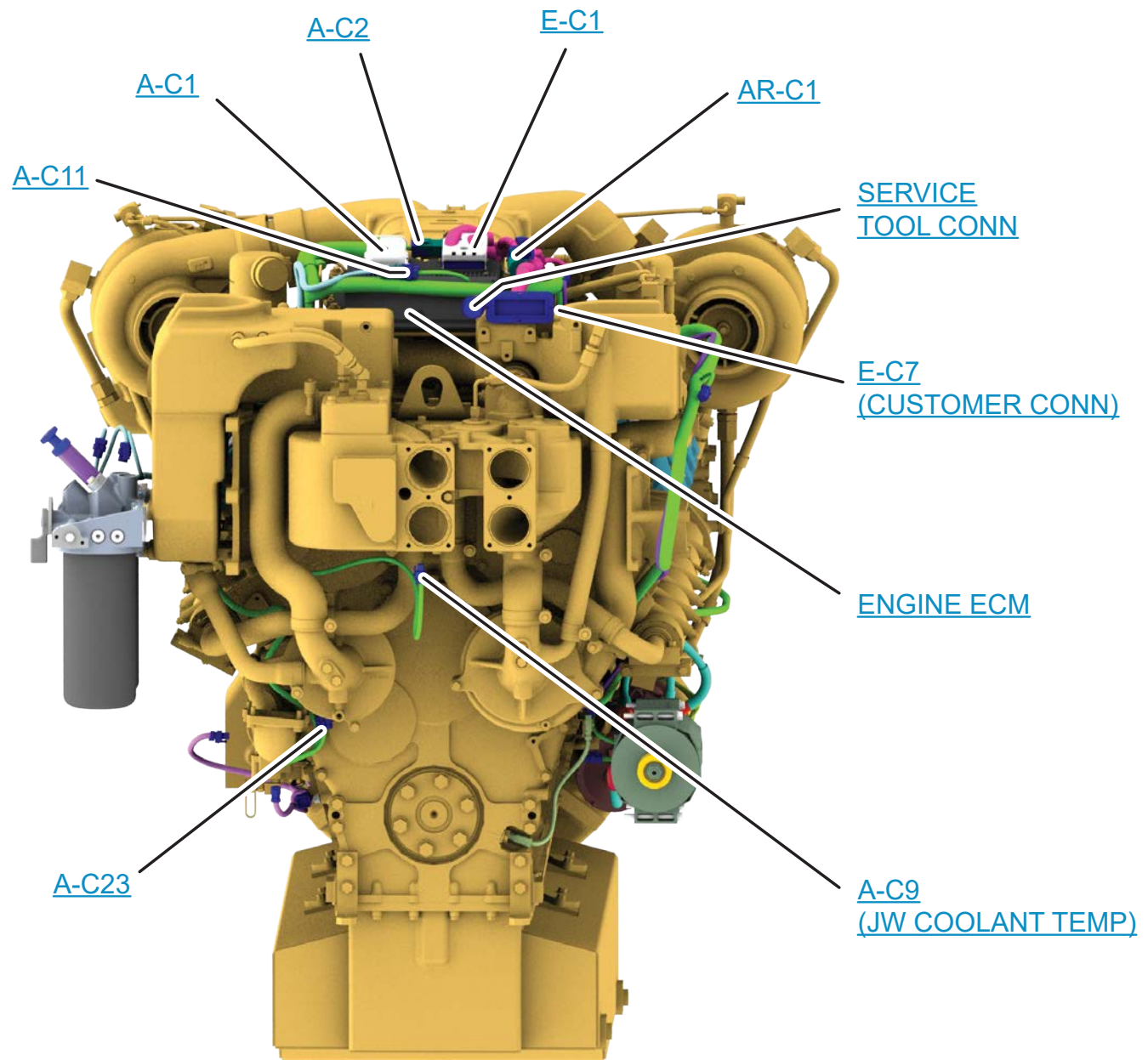

ENGINE RIGHT SIDE VIEW

